

FNS 7794 E

Built-in freezer

with NoFrost and 8 freezer drawers on telescopic runners for max. convenience.



- Ice cubes thanks to the IceMaker with fresh water connection
- Double the convenience with Miele's Ice&PizzaBox
- No icing up of food and no need to defrost thanks to NoFrost
- Optimum and maintenance-free LED lighting in compartment
- Soft closing of the door with SoftClose



EAN: 4002516413691 / Material number: 11730400 / Old Material Number: 37779400GB

Appliance category	
Freezer	•
Construction type	
Built-in appliance	•
Integrated appliance	•
Door hinge	Left
Convertible door hinging	•
Side-by-side enabled	•
Design	
Freezer compartment lighting	LED
IceMaker lighting	•
User convenience	
Networking with Miele@home	•
NoFrost	•
VarioRoom	•
SoftClose	•
Ice cube maker with mains water connection (IceMaker)	•
Controls	
Operating concept	FreshTouch
Independent temperature regulation of fridge and freezer zones	No
SuperFreeze	•
No. of temperature zones	1
Sabbath mode	•
Party mode	•
Freezer/Freezer section	
Number of freezer drawers	8
of which on runners	6
of which Ice&PizzaBox	2
Efficiency and sustainability	
Energy efficiency class (A–G)	E
Annual energy consumption in kWh	236.84
Energy consumption in 24 h in kWh	0.64
Safety	
Lock function	•
Acoustic door alarm	•
Acoustic temperature alarm	•
Optical door alarm	•
Optical temperature alarm	•
Power cut indication for freezer section	•
Technical data	
Niche width in mm min.	560
Niche width in mm max.	570
Niche height in mm min.	1772
Niche height in mm max.	1788
Niche depth in mm	550
Appliance width in mm	559
Appliance height in mm	1770
Appliance depth in mm	544
Weight in kg	70.2

FNS 7794 E

Built-in freezer

with NoFrost and 8 freezer drawers on telescopic runners for max. convenience.



EAN: 4002516413691 / Material number: 11730400 / Old Material Number: 37779400GB

Door hinge technology	Fixed door
Max. door front weight – freezer, in kg	26
Climate class	SN-T
4* freezer compartment in l	213
Freezer capacity in kg/24 h	10.00
Acoustic airborne noise emission class (A–D)	B
Sound emissions in dB(A) re 1 pW	35
Current consumption (mA)	0
Voltage in V	220-240
Fuse rating in A	10
Number of phases	1
Frequency in Hz	50
Length of supply lead in m	2.2
Replacing lamps	Service

FNS 7794 E

Built-in freezer

with NoFrost and 8 freezer drawers on telescopic runners for max. convenience.

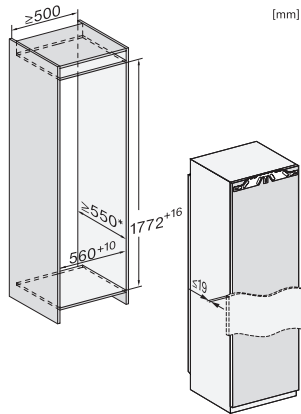

K7733E, K7763E, K7732D, K7732E, K7734F, K7764E, K7743E, K7743D, K7744E, K7773D, K7774D, built-in (footnote*) (drawings)

*The declared energy consumption was calculated in a 560 mm deep niche. The appliance is fully functional in a 550 mm niche but the energy consumption will be slightly higher.

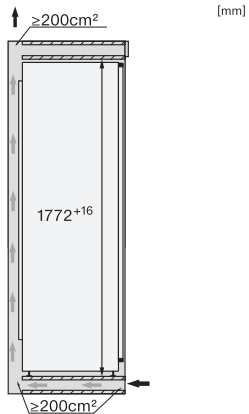

K7733E, K7763E, K7732E, K7734F, K7764E, K7743E, K7743D, K7744E, K7773D, K7774D, side view (installation drawings)

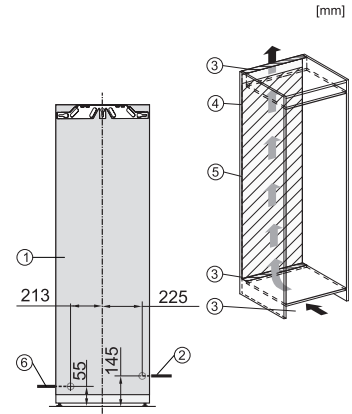

FNS7794E, FNS7794D, installation (footnote*) (installation drawings)

1. Mains connection cable, L = 2100 mm, 2. View from the front, 3. Ventilation cut-out min. 200 cm², 4. Ventilation, 5. No connections permitted in this area, 6. Water connection L = 2000 mm