

**Series 6, Wall-mounted canopy
rangehood, 90 cm, Stainless steel
DWB97LM50A**



**The wall-mounted rangehood: a functional
design element in the kitchen.**

- **Extra silent:** the high-performance rangehood, with minimal noise.
- **Grease filtration level:** filters out over 85% of the grease from kitchen air
- **EcoSilence Drive™:** the powerful, energy-saving drive for hoods.
- **TouchSelect control:** Select rangehood settings via touch with ease.
- **LED lighting:** for perfect, energy-efficient illumination of the cooktop.

Technical Data

Typology : Wall-mounted
Length electrical supply cord : 130 cm
Height of the chimney : 582-908/568-1018 mm
Height of product, without chimney : 46 mm
Minimum distance above an electric cooktop : 550 mm
Minimum distance above a gas cooktop : 650 mm
Net weight : 18.4 kg
Type of control : Electronic
Number of power settings : 3-stages + intensive setting
Maximum output air extraction : 431 m³/h
Boost position output recirculating : 442 m³/h
Maximum output recirculating air : 343 m³/h
Boost position air extraction : 697 m³/h
Number of lights : 3
Noise level : 55 dB(A) re 1 pW
Diameter of air outlet : 120 / 150 mm
Grease filter material : Washable stainless steel
EAN code : 4242005107728
Connection Rating : 145 W
Fuse protection : 10 A
Voltage : 220-240 V
Frequency : 50; 60 Hz
Plug type : AU plug
Installation type : Wall-mounted



Series 6, Wall-mounted canopy rangehood, 90 cm, Stainless steel DWB97LM50A

The wall-mounted rangehood: a functional design element in the kitchen.

Design & Innovation

- Box design
- Appliance colour: Stainless steel

Power and Mode of Operation

- Accessory required for recirculation mode: Standard recirculation kit
- 3 power settings plus intensive setting
- Extraction rate according to EN 61591 ø 15 cm:
max. Normal use: 431 m³/h
Intensive: 697 m³/h
- Extraction rate in recirculation mode:
Max. normal use: 373 m³/h
- Ducted and recirculated-air operation
- Electronic controls with white LED display
- TouchControl
- EcoSilence BLDC brushless motor
- Noise min./max. Normal Level: 45/55 dB
- Noise level in recirculation mode:
Max. normal use: 66 dB(A) re 1 pW (57 dB(A) re 20 µPa sound pressure)
- Energy Efficiency Class: A (at a range of energy efficiency classes from A++ to E)
- Average Energy Consumption: 33.5 kWh/year
- Power rating: 145 W

Comfort & Convenience

- with one-way flap: prevents outside air from entering your kitchen
- Dishwasher safe metal grease filters
- 3 x 1.5 Watt LED Lights
- Intensive operation automatic revert - 6min
- Additional sound insulation mats for optimised sound absorption

Technical Information

- Appliance width: 898 mm
- Dimensions exhaust air (HxWxD): 614-954 x 898 x 500 mm
- Dimensions recirculating (HxWxD): 614-1064 x 898 x 500 mm
- Diameter pipe ø 150 mm (ø 120 mm enclosed)
- Electrical cable length 1.3 m

**Series 6, Wall-mounted canopy rangehood,
90 cm, Stainless steel
DWB97LM50A**

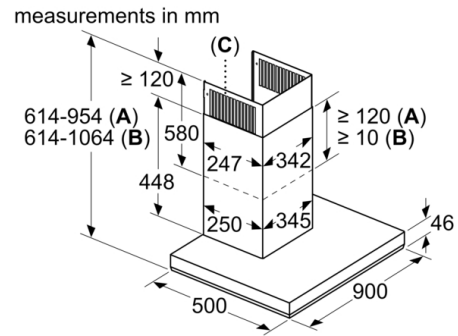
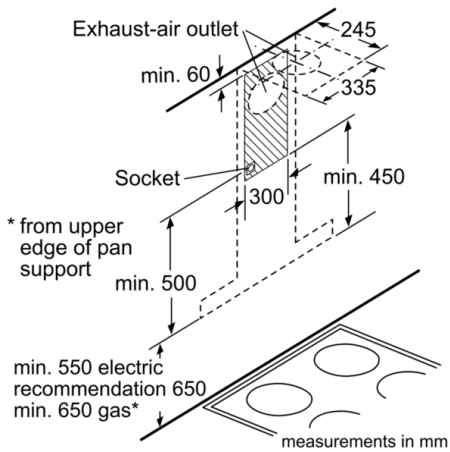

A: Air extraction
B: Air recirculation
C: Air outlet – slots for exhaust air to be mounted facing down

