

LA CORNUÉ

Hotte
Hood
Cappa
Dunstabzugshaube
Campana
Afzuigkap
CornuFé

- FR INSTRUCTIONS POUR L'INSTALLATION, L'EMPLOI
ET L'ENTRETIEN DE LA HOTTE CornuFé
- EN INSTALLATION, USE AND MAINTENANCE OF
HOOD CornuFé
- IT ISTRUZIONE PER L'INSTALLAZIONE, L'USO E LA
MANUTENZIONE DEL PRODOTTO CornuFé
- DE BEDIENUNGSANLEITUNG MIT MONTAGEANWEISUNGEN
FÜR CornuFé
- ES INSTRUCCIONES PARA LA INSTALACIÓN, USO Y MANTENIMIENTO
DEL PRODUCTO CornuFé
- NL INSTRUCTIES VOOR DE INSTALLATIE, HET GEBRUIK EN HET
ONDERHOUD VAN HET PRODUCT CornuFé



- **Warnings**
- **Uses**
- **Dimensions and technical sketch of the product**
- **Conformity to the European directives on the Recycling Of Electrical And Electronic Equipment**
- **Electrical diagram**
- **Installation**
- **Working**
- **Maintenance**

-This appliance can be used by children aged from 8 years and above and persons with reduced physical, sensory or mental capabilities or lack of experience and knowledge if they have been given supervision or instruction concerning use of the appliance in a safe way and understand the hazards involved. Children shall not play with the appliance.

Cleaning and user maintenance shall not be made by children without supervision.

Children less than 8 years of age shall be kept away unless continuously supervised.

- Do not flambé under the range hood

- **WARNING:** Accessible parts can become very hot if used with cooking appliances.

- There shall be adequate ventilation of the room when the range hood is used at the same time as appliances burning gas or other fuels (not applicable to appliances that only discharge the air back into the room);

- Air captured shall not be conveyed in a duct used for the discharge of fumes from appliances burning gas or other fuels.

- After changing the transmission code on the radio control, it is necessary to transmit the new code to the electronic control board of the range hood, in the following way : push the red button placed inside the range hood (Fig.9) and turn it to the "OFF" position and then back to the "ON" position after a few seconds. In this way, the electronic control board is disconnected and reconnected to power supply. Push the light button in the radio control within the next 15 seconds, in order to synchronise the range hood with the radio control.

WARNINGS

– READ AND SAVE THESE INSTRUCTION before installing and using this product.

We are not responsible for any damage or fire caused by the non-respect of the warnings described in this manual.

– Keep this manual with you. If you sell or leave this unit in the future, the new customer will be informed about the functioning and the warnings here described.

– The cooker surface and the inferior part of the cooker hood must be at a minimum distance of 65 cm.

– Air captured shall not be conveyed in a duct used for the discharge of fumes from appliances burning gas or other fuels. (eg. centralized heating, radiators, water-heaters, etc.).

– To evacuate the air outlet, please comply with the pertaining rules given by competent authorities.

– There shall be adequate ventilation of the room when the range hood is used at the same time as appliances burning gas or other fuels (not applicable to appliances that only discharge the air back into the room); (gas-, oil-, or coal-stoves, etc.) are used simultaneously. The cooker hood, when evacuating the sucked air, could generate a negative pressure in the room– which can't exceed the limit of 0.04 mbar, in order to avoid the suck of exhausts deriving from the heat-source. Therefore the room should be provided with air-intakes to allow a constant flow of fresh air.

– When performing the electrical connections on the appliance, please make sure that the current-tap is provided with earth connection and that voltage values correspond to those indicated on the label placed inside the appliance itself.

– Before carrying out any cleaning or maintaining operations, the appliance needs to be removed from the electric grid.

– If the appliance is not provided with a non-separable flexible cable and plug, or with another device ensuring omnipolar disconnections from the grid, with an opening distance between the contacts of at least 3 mm, then such disconnecting devices must be supplied within the fixed installation.

– If the fixed appliance is endowed with a supply cord and a plug, the appliance has to be put in a place where the plug can be reached easily.

– Do not flambé under the range hood.

– WARNING: Accessible parts can become very hot if used with cooking appliances.

– Warning: Failure to install the screws or fixing device in accordance with these instructions may results in electrical hazards.

WARNING – TO REDUCE THE RISK OF FIRE, ELECTRIC SHOCK, OR INJURY TO PERSONS, OBSERVE THE FOLLOWING

- A)** Use this unit only in the manner intended by the manufacturer. If you have questions, contact the manufacturer
- B)** Before servicing or cleaning unit, switch power off at service panel and lock the service disconnecting means to prevent power from being switched on accidentally. When the service disconnecting means cannot be locked, securely fasten a prominent warning device, such as a tag, to the service panel.
- C)** Installation work and electrical wiring must be done by qualified person(s) in accordance with all applicable codes and standards, including fire-rated construction.
- D)** Sufficient air is needed for proper combustion and exhausting of gases through the flue (chimney) of fuel burning equipment to prevent back drafting. Follow the heating equipment manufacturer's guideline and safety standards such as those published by the National Fire Protection Association (NFPA), and the American Society for Heating, Refrigeration and Air Conditioning Engineers (ASHRAE), and the local code authorities.
- E)** When cutting or drilling into wall or ceiling, do not damage electrical wiring and other hidden utilities
- F)** Ducted fans must always be vented to the outdoors

WARNING – TO REDUCE THE RISK OF FIRE, USE ONLY METAL DUCTWORK.

WARNING – TO REDUCE THE RISK OF A RANGE TOP GREASE FIRE:

- A)** Never leave surface units unattended at high settings. Boilovers cause smoking and greasy spillovers that may ignite. Heat oils slowly on low or medium settings
- B)** Always turn hood ON when cooking at high heat or when flambeing food (i.e. Crepes Suzette, Cherries Jubilee, Peppercorn Beef Flambe').
- C)** Clean ventilating fans frequently. Grease should not be allowed to accumulate on fan or filter.
- D)** Use proper pan size. Always use cookware appropriate for the size of the surface element.

WARNING - TO REDUCE THE RISK OF INJURY TO PERSONS IN THE EVENT OF A RANGE TOP GREASE FIRE, OBSERVE THE FOLLOWING:

A) SMOTHER FLAMES with a close-fitting lid, cookie sheet, or metal tray, then turn off the burner. BE CAREFUL TO PREVENT BURNS. If the flames do not go out immediately, EVACUATE AND CALL THE FIRE DEPARTMENT.

B) NEVER PICK UP A FLAMING PAN - You may be burned.

C) DO NOT USE WATER, including wet dishcloths or towels - a violent steam explosion will result.

D) Use an extinguisher ONLY if:

- 1) You know you have a Class ABC extinguisher, and you already know how operate it.
- 2) The fire is small and contained in the area where it started
- 3) The fire department is being called.
- 4) You can fight the fire with your back to an exit.

USES

The appliance is already arranged both for filtering and for suction performances.

In its filtering version (Fig.1), the air and fumes conveyed by the appliance are cleaned both by a grease filter and by an active coal filter, and put again into circulation through the side-grids of the chimney.

In its sucking version (Fig.2), fumes are directly conveyed outside, through an evacuation duct connected with the superior part of the wall or the ceiling. Both coal filter and air deflector are not necessary in this case.

DIMENSIONS AND TECHNICAL SKETCH OF THE HOOD

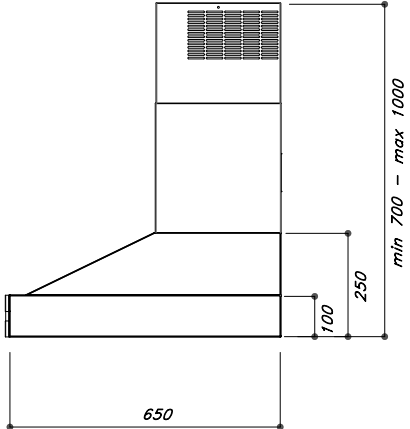
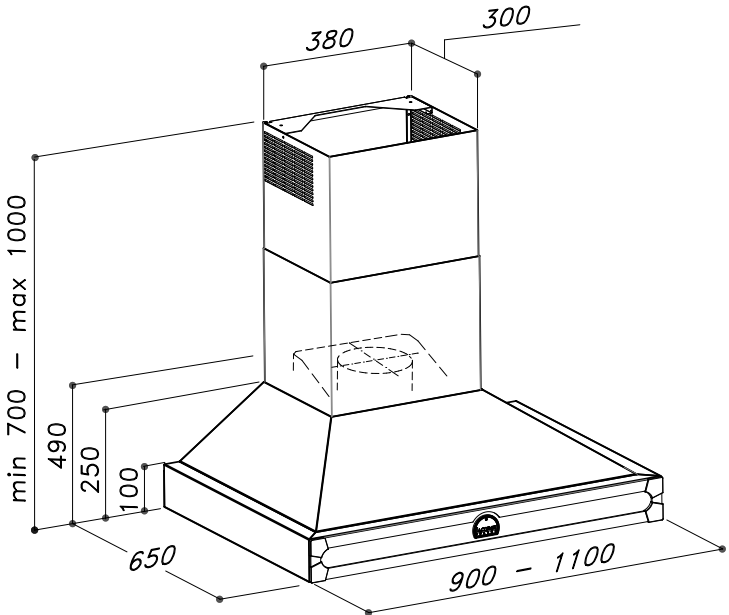

| Motor 1000m3/h - Alluminium EUR 230V | | | | |
|---|------------|-------------|----------|------------|
| speed | Capacity | Noise level | Pressure | Absorption |
| 1° | 330 m3/h | 45 dba | 275 Pa | W 90 |
| 2° | 490 m3/h | 50 dba | 410 Pa | W 145 |
| 3° | 730 m3/h | 56 dba | 440 Pa | W 250 |
| 4° | 1.000 m3/h | 63 dba | 480 Pa | W 265 |

3 X lamp 20W
 2 X filter 415mmX350mmX25mm
 Air outlet 150mm

| Motor 600cfm - Alluminium USA 120V | | | | |
|---|-----------|-------------|----------|------------|
| speed | Capacity | Noise level | Pressure | Absorption |
| 1° | 330 m3/h | 41 dba | 280 Pa | W 120 |
| 2° | 490 m3/h | 50 dba | 470 Pa | W 175 |
| 3° | 730 m3/h | 56 dba | 500 Pa | W 280 |
| 4° | 1000 m3/h | 63 dba | 620 Pa | W 320 |

3 X lamp 20W
 2 X filter 415mmX350mmX25mm
 Air outlet 150mm

CONFORMITY TO THE EUROPEAN DIRECTIVES ON THE RECYCLING OF ELECTRICAL AND ELECTRONIC EQUIPMENT

All of our products are conforming to the following European directives:

Directive 2006/95/ CE “LOW TENSION”

Directive 2004/108/ CE “ELECTROMAGNETIC COMPATIBILITY”

Directive 2012/19/ CE “RAEE” – “DISPOSAL OF ELECTRIC EQUIPMENTS AND ELECTRONICS”

Directive 2002 / 95/ CE “RoHS” – “LIMITATION OF DANGEROUS SUBSTANCES”

RECYCLING OF ELECTRICAL AND ELECTRONIC EQUIPMENT



The symbol on the product or on its packaging indicates that this product may not be treated as household waste.

Instead it shall be handed over to the applicable collection point for the recycling of electrical and electronic equipment.

By ensuring this product is disposed of correctly, you will help prevent potential negative consequences for the environment and human health, which could otherwise be caused by inappropriate waste handling of this product.

For more detailed information about recycling of this product, please contact your local city office, your household waste disposal service or the shop where you purchased the product.

This appliance is marked according to the European directive 2012/19/CE.

On waste electrical and electronic equipment (WEEE).

Compliance with directives and standards

Range hoods manufactured for USA and Canada are cCSAus certified according to standard requirements.

INSTALLATION

Before installing the appliance, in order not to damage the appliance itself, the metal grease filter should be removed. Such filter can be removed by pushing the special filter handle toward the back side of the cooker hood and turning it downwards so to unfasten it from its slot (Fig. 3).

By using the special drilling jig (Fig. 4), perforate the wall according to the pattern indicated by the jig itself, and pay attention in order not to damage water pipes and electric wires.

Perforation should be performed with a \varnothing 8 mm wall-drill.

Then insert into the proper plastic reinforcements.
 The hood-bearing stirrup can be applied by using the screws provided with the equipment.
 Now hook the cooker hood onto its bearing and then adjust horizontally and vertically the position of the appliance by acting on the special metric screws.
 to complete the installation insert the two fixing screws in the rear of the cooker hoods in the 2 holes previously made.
 Before fixing the chimneys connect the power supply behind the decorative chimney.
 Install the chimneys on the hood by raising the upper chimneys till the height required and secure the fixing brackets with the screws and the washers supplied.(Fig. 8)
 Afterwards raise the upper chimney and secure it through the 2 lateral screws.(Fig. 9).

ELECTRICAL DIAGRAM

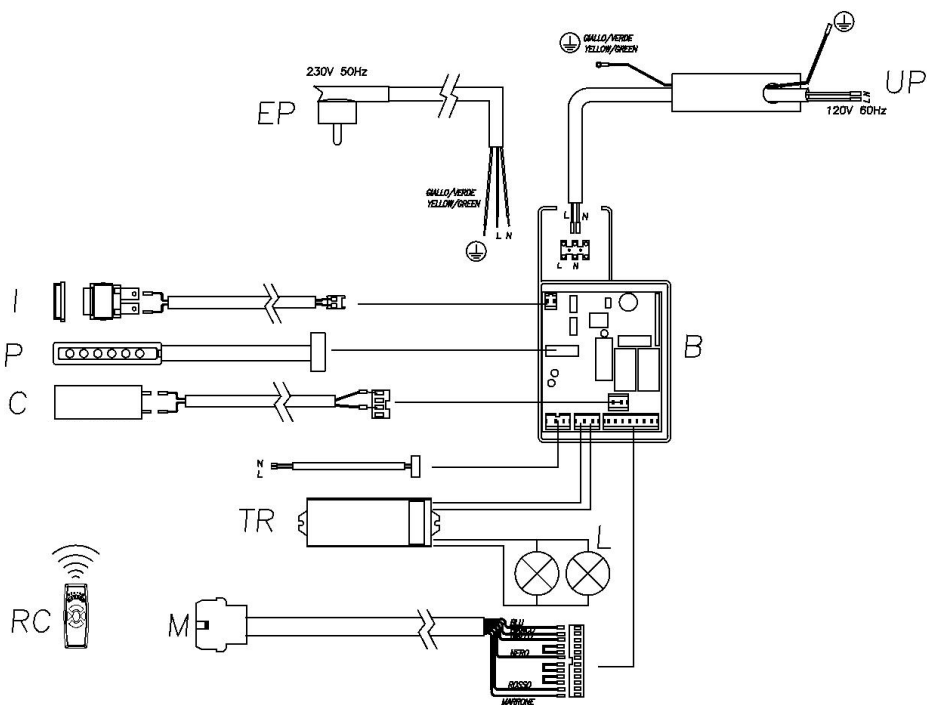

| | |
|-----------|---------------------------|
| UP | USA POWER SUPPLY SUT69 |
| EP | EUROPE POWER SOPPLY SLT69 |
| B | ELECTRONIC CARD |
| I | GENERAL SWITCH |
| P | CONTROLS |
| RC | REMOTE CONTROLS |
| TR | transformer 12V |
| M | MOTOR |
| L | HALOGEN LAMP |
| C | CAPACITORS |

WORKING

RC001

RADIO CONTROL

Radio control used for the remote operation of ducted cooker hoods.

TECHNICAL DATA

- Alkaline battery powered: 12 V mod. 27A
- Operating frequency: 433.92 Mhz
- Combinations: 32.768
- Max. consumption: 25 mA
- Operating temperature: -20 ÷ + 55 °C
- Dimensions: 130x45x15 mm.

OPERATING DESCRIPTION

The transmitter is equipped with 5 buttons for cooker hood management, as specified below:

- ☀ : Light ON/OFF command.
- ⏻ : Motor ON (speed level 1) / OFF command.
- : Reduce speed.
- + : Increase speed.
- ⌚ : 10-minute timer.

INITIAL OPERATING CONDITION

The manufacturer supplies the radio control unit ready to be used with codes preset in the Factory



OPERATION MODE

Standard configuration:

Standard configuration requires all “cooker hoods - radio control - system” to be provided with the same transmission code. In the event two cooker hoods - radio control system are installed in the same room or nearby, each system may affect the operation of the another. Therefore, the code of one radio control system must be changed.

Generating a new transmission code:

The radio control system is provided with preset codes. Should new codes be required, proceed as follows: Press simultaneously buttons:



for two seconds. When Leds light on, press buttons:

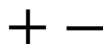

(within 5 seconds). Leds flashing 3 times indicate the procedure is completed.

WARNING! This operation deletes permanently the preset codes.

Learning the new transmission code:

Once the transmission code is changed in the radio control unit, the electronic central unit of the cooker hood must be made to set the new code in the following way:

Press the main power-off button of the hood and then restore power to the electronic control unit. Within the next 15 seconds, press the Light Button ☀ to synchronise the central unit with the code.

Reset of the Factory configuration:

To restore the Factory configuration, follow the procedure described below: press simultaneously buttons:



for 2 seconds. When Leds light on, press buttons:

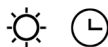

(within 5 seconds). Leds flashing 6 times indicate the procedure is completed.

WARNING! This operation deletes permanently the preset codes.

Emergency button:

In the event that the radio control does not work, use the emergency button to switch the appliance off. After any necessary repairs have been performed, reset the emergency button.

WARNING

The battery should be replaced every year to guarantee the optimal range of the transmitter.

To replace the exhausted battery, take the plastic lid off, remove the battery and replace it with a new one, observing the correct battery polarities.

Used batteries should be discarded in special collection bins.

The below product:
RC001 Radio Control
complies with the specifications set out in the
Directive RED 2014/53/EU.



WARNING

Any adjustments or modifications which have not been expressly approved by the holder of the legal conformity certificate may invalidate the user's rights relating to the operation of the device.

TIMING

As a result of the new EU65 "Energy label" and EU66 " Ecodesign" regulations issued by the European Commission, which came into force as from January 1st, 2015 , our products have been adapted to comply with these new requirements. All of the models complying with the energy label requirements, are equipped with new electronics including a timer device for suction speeds control, when the air capacity exceeds 650m³/h. Internal motor models, with maximum air capacity higher than 650m³/h, are equipped with a timer device that automatically switches the suction speed from 4th to 3rd speed, after 5 minutes operation. Stand - by mode is lower than 0.5W.

MAINTENANCE

An accurate maintenance guarantees good functioning and long-lasting performance.

Particular care is due to the grease filter panel.

It can be removed by pushing its special handle toward the back-side of the cooker hood and turning the filter downwards so to unfasten it from its slot (Fig.3).

To insert the filter just perform the opposite operation.

After 30 hours working, the push button control panel will signal the saturation of the grease filter by lighting all the buttons.

Press the timer button to reset.

The grease filter needs cleaning by regular hand-washing or in dishwashers every two months at least or depending on its use.

To clean the appliance itself tepid water and neutral detergent are recommended, while abrasive products should be avoided. For steel appliances specialized detergents are recommended.

To replace the dichroic lamp, remove the lamp by inserting a screwdriver or another sharp tool between the lamp and its chrome support and replace it with a lamp of the same kind 20W 12V

If the supply cord is damaged, it must be replaced by the manufacturer or its service agent or a similarly qualified person in order to avoid a hazard.

WARRANTY (5 YEARS)

Following receipt of full payment for our goods, our appliances are guaranteed five years from the invoice date against any structural faults and any material defects. The warranty excludes improper use of the appliance or a non-compliant installation. Intervention and travel costs will be billed in this event.

If our goods were to dysfunction, the buyer then has to contact us once he has ensured that it is not due to a non-compliant installation or abnormal use in order to decide with us how the appliance should be repaired. The appliance should be cleaned and clean prior to any intervention.

Any complaints with regard to the state, the presentation or the non-compliance of our goods should be addressed to our headquarters by recommended letter with acknowledgement of receipt within a maximum of eight days following delivery.

The application of the warranty will be subject to LA CORNUE SAS receiving a certificate stating that the material has been installed by a professional in accordance with the current technical and safety standards.

Under this warranty, the seller shall replace at no cost the parts recognized as faulty by its technical department. This warranty covers labour costs and travelling expenses.

The warranty period specified above shall not be extended if faulty parts need to be replaced.

WE TAKE GREAT CARE IN THE CREATION OF OUR ENAMELLED ITEMS. However, a hand-crafted enamel surface is never completely even and slight variations in shade may occur. This is a guarantee of quality and is linked to the nature of our enamelling process.

This warranty shall cease to apply:

- If the operational defect is the result of an unauthorized intervention on the appliance;
- If the faulty operation is due to normal wear and tear of the appliance or from negligence or insufficient maintenance by the buyer;
- If the faulty operation is due to force majeure.

LA CORNUE SAS shall not be held legally responsible in these three cases.

The seller's guarantee and his responsibility for products shall be limited to repairs to any defects as stipulated in the above conditions.

As expressly agreed between the contracting parties, the seller's responsibility in the event of an operational fault shall be limited to the above provisions, especially with regard to concealed defects as well as material and immaterial damage.

In all cases, the buyer may not suspend payment if he lodges a complaint about the quality of the goods.

The goods are always transported at the buyer's or his representative's own risks. It is therefore their responsibility to check them upon arrival and, if necessary, to lodge a complaint with the haulier. After having expressed specific established reservations on the delivery slip upon receipt, the buyer must confirm them by recommended letter to the haulier within two days of receipt (Article 105 of the Commercial Code).

We cannot in any event honour this warranty if these requirements are not met.

After-Sales Department:

Tel: +33 (0)1 34 48 36 15 fax: +33 (0)1 34 48 52 31

E-mail: service@la-cornue.com

Fig. 1

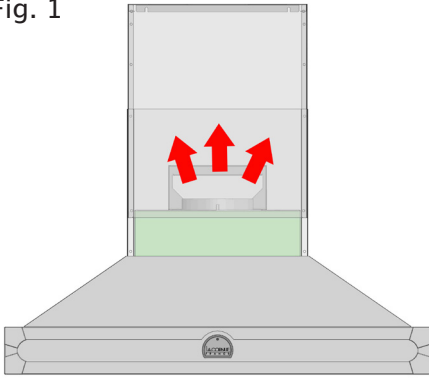

Fig. 2

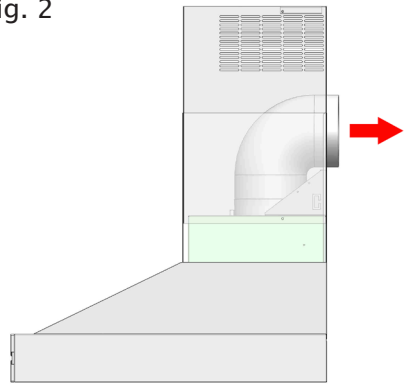

Fig. 3

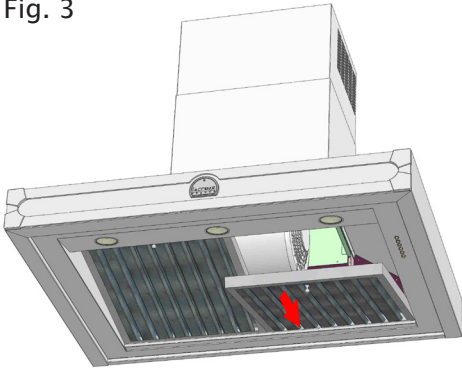

Fig. 4

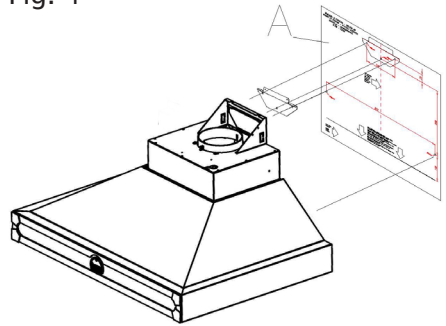

Fig. 5

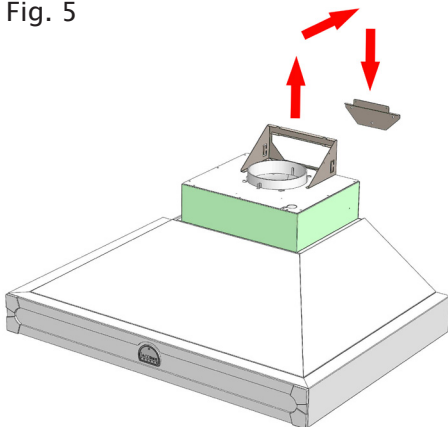

Fig. 6

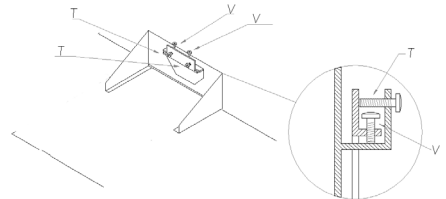

Fig. 7

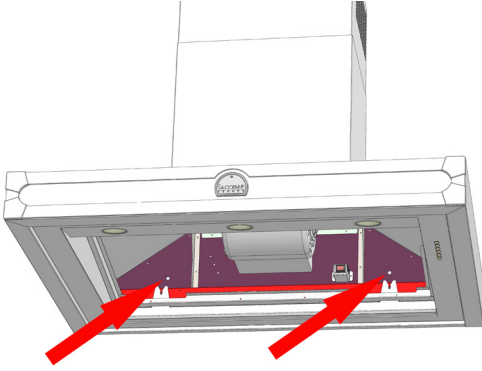

Fig. 8

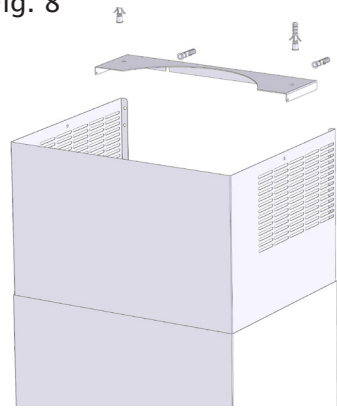

Fig. 9

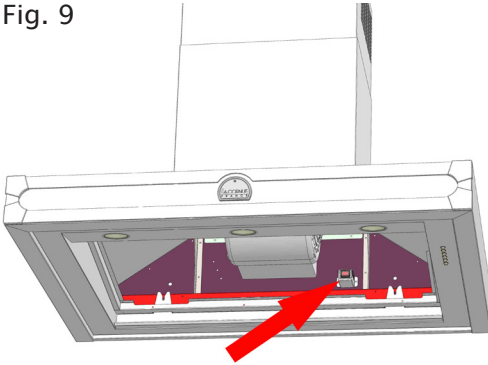
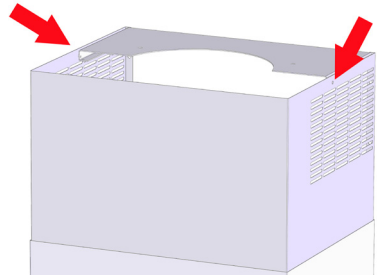

Fig. 10



LA CORNUE



Ateliers La Cornue

14, rue du Bois du Pont - Z.I. les Béthunes - 95310 Saint-Ouen-l'Aumône
FRANCE

Adresse postale :

La Cornue SAS - B.P. 99006 - 95070 Cergy-Pontoise Cedex - FRANCE

Tél. : +33 (0)1 34 48 36 36 – Fax : +33 (0)1 34 64 32 65

E-mail : a.table@la-cornue.com

www.lacornue.com