

FAB REFRIGERATION

FAB38 50'S STYLE RETRO REFRIGERATOR

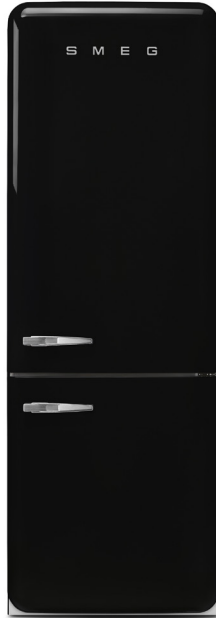

Finish	Black, White, Cream, Red, Pastel Blue, and Pastel Green
Dimensions	706mmW x 2060mmH x 811mmD (includes handle)
Volume	Refrigerator: 355L Freezer: 155L Total: 510L

REFRIGERATOR

No. Shelves	3 x Quick chill glass
No. Drawers	1 x Crisper drawer 1 x Life Plus 0°C drawer
Lighting	LED

Inner Fridge Door

No. Shelves	3 x Adjustable glass shelves 1 x Bottle glass shelf
-------------	--

FREEZER

No. Shelves	2 x Glass shelves
No. of drawers	2 x plastic drawers
Accessories	1 x Fast freezing compartment
Defrost	Total Frost Free

Performance

Energy Consumption	328kWh/per year
Star Rating	4.5 Star
Noise	41 dBA
Power	220-240V, 50/60Hz 10A (3-pin plug)
Warranty	5 years parts and labour

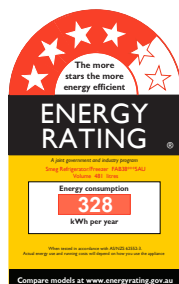

PERFECT BLEND OF ARTISTRY & FUNCTIONALITY

Like other timeless designs, the original Smeg FAB refrigerator is more than just a mere fridge. It's the focal point of the kitchen, bringing together unquestionable style and premium performance. Always evocative and eclectic, FAB fridges have become standard bearers for "Made in Italy" design all over the world with their inimitable blend of artistry and functionality.

DOUBLE ZONE ELECTRONIC TEMPERATURE CONTROL

The digital electronic control panel at the top of the fridge provides accurate temperature monitoring in both the fridge and freezer compartments to ensure the long life of perishable food. With three functions: ECO, fast freezing and temperature alarm, the FAB38 optimises freshness and reduces food waste. FUNCTIONS: ECO, Fast freezing, & Temperature alarm

MULTI-COOLING NO FROST TECHNOLOGY

Thanks to the no frost system you won't have to manually defrost the freezer as cool air is circulated inside to prevent any icy build ups and maximise storage capacity.

LIFE PLUS 0°C DRAWER

This chilling drawer provides a controlled temperature zone for better and longer preservation of perishable food such as meat, fish, fruit and vegetables and dairy products.



ID211108

FAB REFRIGERATION

FAB38
50'S STYLE RETRO REFRIGERATOR

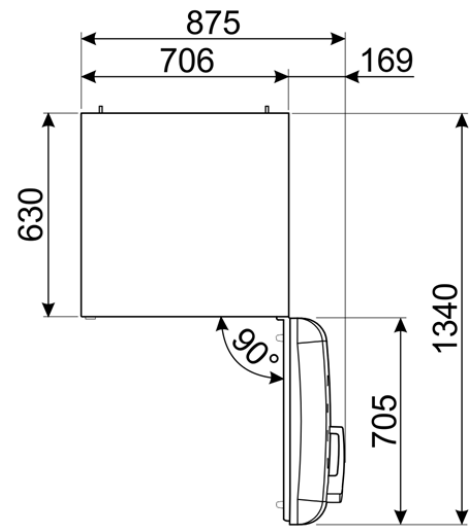
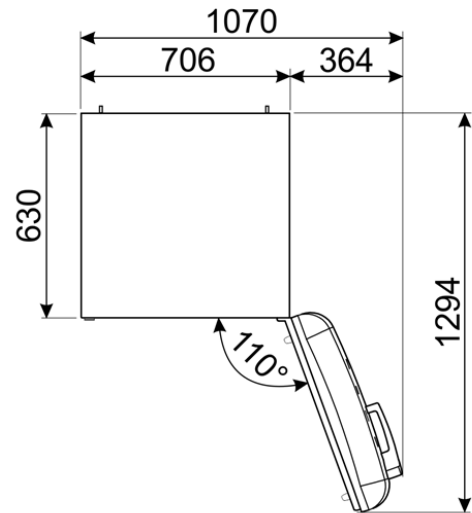
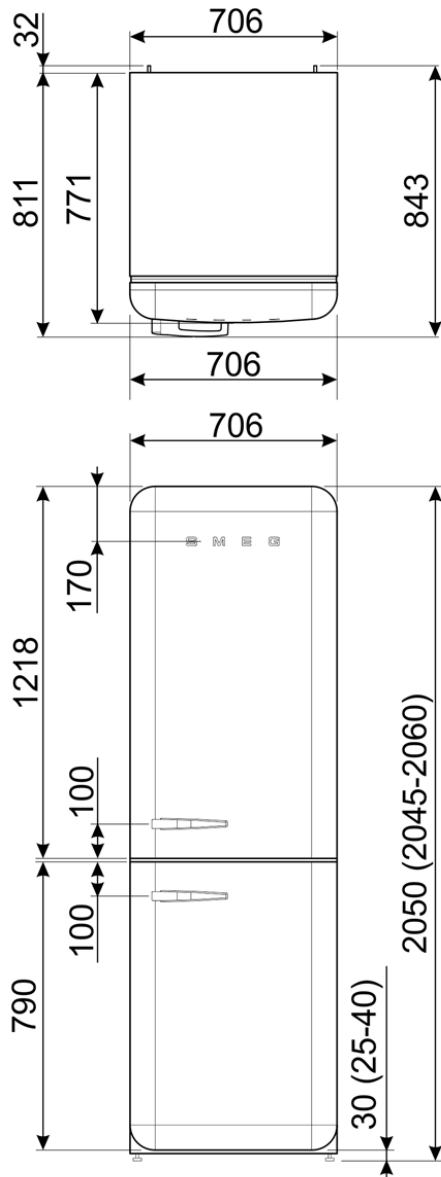

PLEASE NOTE: drawings are not to scale. They are to assist only.
WARNING: technical specifications and product sizes can be varied by the manufacturer without notice.
Cutouts for appliances should only be by physical product measurements. The above information is indicative only.

FAB REFRIGERATION

FAB38
50'S STYLE RETRO REFRIGERATOR



FAB38RBL5AU
Black



FAB38RWH5AU
White



FAB38RCR5AU
Cream



FAB38RPB5AU
Pastel Blue



FAB38RPG5AU
Pastel Green



FAB38RRD5AU
Red