

# FS61XNG8-1

Cooker size	60x60 cm
N. of cavities with energy label	1
Hob type	Gas
Type of main oven	Static
EAN code	8017709310776



## Aesthetics



<b>Serie</b>	Concerto	<b>Controls colour</b>	Stainless steel
<b>Aesthetic</b>	Classic	<b>Display</b>	Touch
<b>Colour</b>	Stainless steel	<b>No. of controls</b>	6
<b>Finishing</b>	Satin	<b>Serigraphy colour</b>	Black
<b>Design</b>	Standard	<b>Handle</b>	Smeg Classic
<b>Door</b>	With 2 horizontal strips	<b>Handle Colour</b>	Brushed stainless steel
<b>Upstand</b>	Yes	<b>Glass type</b>	Stopsol
<b>Type of pan stands</b>	Cast Iron	<b>Feet</b>	Silver
<b>Hob colour</b>	Stainless steel	<b>Storage compartment</b>	Door
<b>Command panel finish</b>	Stainless steel	<b>Logo</b>	Embossed
<b>Control knobs</b>	Smeg Classic	<b>Logo position</b>	Facia below the oven

## Programs / Functions

**No. of cooking functions** 6

**Traditional cooking functions**



Static



Circulaire



Large grill



Fan grill (large)



Base



Fan assisted bottom

**Cleaning functions**



Vapour Clean

## Hob technical features

			
<b>Total no. of cook zones</b> 4			
Front left - Gas - UR - 4.00 kW			
Rear left - Gas - Semi Rapid - 1.80 kW			
Rear right - Gas - Semi Rapid - 1.80 kW			
Front right - Gas - AUX - 1.00 kW			
<b>Type of gas burners</b>	Standard	<b>Gas safety valves</b>	Yes
<b>Automatic electronic ignition</b>	Yes	<b>Burner caps</b>	Matt black enamelled

## Main Oven Technical Features



<b>No. of lights</b>	1	<b>Removable inner door</b>	Yes
<b>Fan number</b>	1	<b>Total no. of door glasses</b>	3
<b>Net volume of the cavity</b>	72 l	<b>No. of thermo-reflective door glasses</b>	2
<b>Gross volume, 1st cavity</b>	79 l	<b>Safety Thermostat</b>	Yes
<b>Cavity material</b>	Ever Clean enamel	<b>Cooling system</b>	Tangential
<b>No. of shelves</b>	5	<b>Usable cavity space dimensions (HxWxD)</b>	360x444x425 mm
<b>Type of shelves</b>	Metal racks	<b>Temperature control</b>	Electro-mechanical
<b>Light type</b>	Halogen	<b>Lower heating element power</b>	1200 W
<b>Light Power</b>	40 W	<b>Upper heating element - Power</b>	1000 W
<b>Cooking time setting</b>	Start and Stop	<b>Grill element</b>	1700 W
<b>Light when oven door is open</b>	Yes	<b>Circular heating element - Power</b>	2000 W
<b>Removable door</b>	Yes	<b>Grill type</b>	Electric
<b>Full glass inner door</b>	Yes		

## Options Main Oven

<b>Timer</b>	Yes	<b>Minimum Temperature</b>	50 °C
<b>End of cooking acoustic alarm</b>	Yes	<b>Maximum temperature</b>	260 °C

## Accessories included for Main Oven & Hob



<b>Cast iron wok support</b>	1	<b>Grill mesh</b>	1
<b>Rack with back and side stop</b>	2	<b>Telescopic Guide rails, partial Extraction</b>	1
<b>40mm deep tray</b>	1		

## Electrical Connection

<b>Plug</b>	(I) Australia	<b>Frequency</b>	50/60 Hz
<b>Electrical connection rating</b>	2200 W	<b>Power supply cable length</b>	120 cm
<b>Current</b>	10 A	<b>Terminal block</b>	3 poles
<b>Voltage</b>	220-240 V		

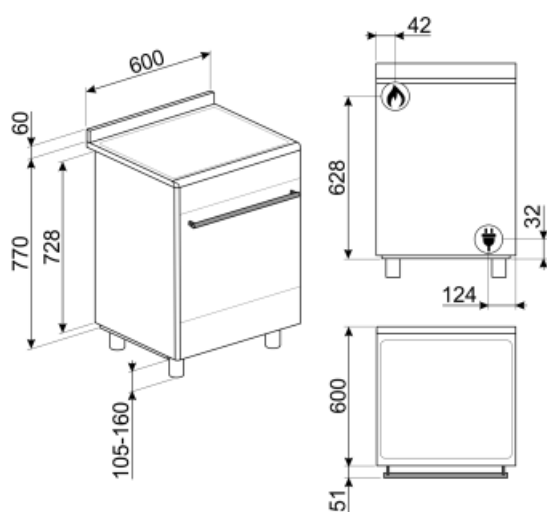

## Not included accessories



**SFLK1**  
Child lock



**PRTX**  
Refractory pizza stone with handles. D=35cm Not suitable for microwave ovens. Suitable for gas ovens, to be put on the griddle.



**BG6090-1**  
Cast iron grill plate suitable for Concerto cookers



**BN620-1**  
Enamelled tray, 20mm deep



**KITPDQ**  
Height reduction feet (850 mm), stainless steel, for cookers



**PALPZ**  
Pizza shovel with fold away handle width: 315mm length : 325mm



**GTT**  
\*\*Totally extractable telescopic guides (1 level)\*\* Extraction: 433 mm Material: Stainless steel AISI 430 polished

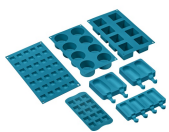

**SMOLD**  
Set of 7 silicone moulds for ice creams, ice lollies, pralines, ice cubes or to portion food. Usable from -60°C to +230°C



**GTP**  
\*\*Partially extractable telescopic guides (1 level)\*\* Extraction: 300 mm Material: Stainless steel AISI 430 polished



**BNP608T**  
Teflon-coated tray, 8mm depth, to be placed on the grid



**KITH95**  
Height extension kit (950 mm), stainless steel



**PPX6090-1**  
Stainless steel grill plate suitable for 90 cm Concerto cookers



**AL60**  
Upstand suitable for 60 cm Concert cookers with gas hob





















**KITP60X9**  
Splashback, 90 cm, stainless steel, suitable for pyrolytic Concerto cookers



**BN640**  
Enamelled tray, 40mm deep

## Symbols glossary (TT)

 <p>Heavy duty cast iron pan stands: for maximum stability and strength.</p>	 <p>Air cooling system: to ensure a safe surface temperatures.</p>
 <p>Triple glazed doors: Number of glazed doors.</p>	 <p>Enamel interior: The enamel interior of all Smeg ovens have a special antacid lining which helps keep the interior clean by reducing the amount of cooking grease adhering to it.</p>
 <p>Circogas: In gas ovens the fan distributes the heat quickly and evenly throughout the oven cavity, avoiding flavour transfer when cooking a number of different dishes at the same time. In electric ovens this combination completes cooking more quickly of foods that are ready on the surface, but that require more cooking inside, without further browning.</p>	 <p>Upper and lower element only: a traditional cooking method best suited for single items located in the centre of the oven. the top pf the oven will always be hottest. Ideal for roast, fruit cakes, bread etc.</p>
 <p>Lower heating element only: This function is ideal for foods that require extra base temperature without browning, e.g. pastry dishes, pizza. Also suitable for slow cooking of stews and casseroles.</p>	 <p>Circulaire: The combination of the fan and circular element around it gives a hot air cooking method. This provides many benefits including no preheat if cook time is more than 20 minutes, no flavour transfer when cooking different foods at the same time, less energy, and shorter cook times. Good for all types of food.</p>
 <p>Grill element: Using of grill gives excellent results when cooking meat of medium and small portions, especially when combined with a rotisserie (where possible). Also ideal for cooking sausages and bacon.</p>	 <p>Fan with grill element: The fan reduces the fierce heat from the grill, providing an excellent method of grilling various foods, chops, steaks, sausages etc. giving even browning and heat distribution, without drying out the food. The top two levels recommended for use, and the lower part of the oven can be used to keep items warm at the same time, an excellent facility when cooking a grilled breakfast. Half grill (centre portion only) is ideal for small quantities of food.</p>
 <p>All glass inner door: All glass inner door, a single flat surface which is simple to keep clean.</p>	 <p>The inner door glass: can be removed with a few quick movements for cleaning.</p>
 <p>Side lights: Two opposing side lights increase visibility inside the oven.</p>	 <p>The oven cavity has 5 different cooking levels.</p>
 <p>Telescopic rails: allow you to pull out the dish and check it without having to remove it from the oven entirely.</p>	 <p>Ultra rapid burners: Powerful ultra rapid burners offer up to 5kw of power.</p>
 <p>Vapour Clean: a simple cleaning function using steam to loosen deposits in the oven cavity.</p>	 <p>The capacity indicates the amount of usable space in the oven cavity in litres.</p>