

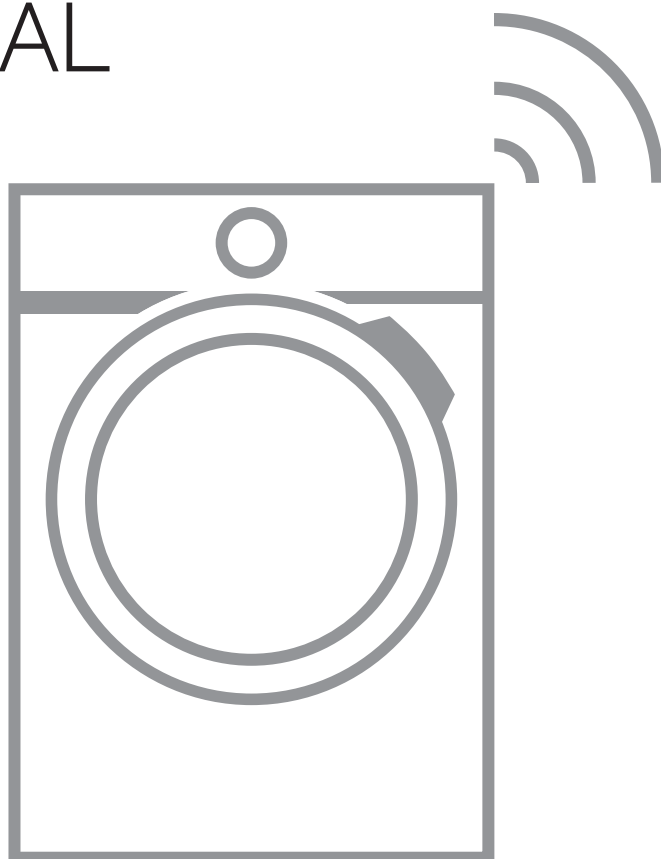

USER MANUAL



CONTENTS

1. SAFETY INFORMATION.....	3
2. SAFETY INSTRUCTIONS.....	5
3. PRODUCT DESCRIPTION.....	7
4. TECHNICAL DATA.....	8
5. INSTALLATION.....	9
6. CONTROL PANEL.....	14
7. DIAL AND BUTTONS.....	17
8. SETTINGS.....	20
9. BEFORE FIRST USE.....	21
10. PROGRAMS.....	21
11.  WI-FI - CONNECTIVITY SETUP.....	27
12. DAILY USE.....	29
13. HINTS AND TIPS.....	35
14. CARE AND CLEANING.....	36
15. TROUBLESHOOTING.....	42
16. QUICK GUIDE	47
17. WARRANTY - AUSTRALIA AND NEW ZEALAND.....	49
18. ENVIRONMENTAL CONCERNS.....	51

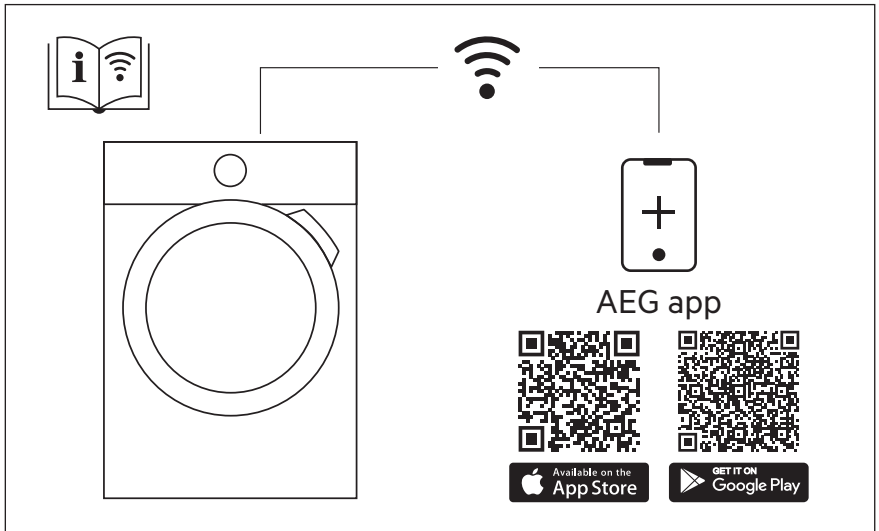

IMPORTANT INFORMATION THAT MAY IMPACT YOUR MANUFACTURER'S WARRANTY

Adherence to the directions for use in this manual is extremely important for health and safety. Failure to strictly adhere to the requirements in this manual may result in personal injury, property damage and affect your ability to make a claim under the AEG manufacturer's warranty provided with your product. Products must be used, installed and operated in accordance with this manual. You may not be able to claim on the AEG manufacturer's warranty in the event that your product fault is due to failure to adhere to this manual.

FOR PERFECT RESULTS

Thank you for choosing this AEG product. We have created it to give you impeccable performance for many years, with innovative technologies that help make life simpler features you might not find on ordinary appliances. Please spend a few minutes reading to get the very best from it.

Visit our website for:



Get usage advice, brochures, trouble shooter, service information:

www.aeg.com



Register your product for better service:

www.registeraeg.com



Buy Accessories, Consumables and Original spare parts for your appliance:

www.aeg.com/shop

CUSTOMER CARE AND SERVICE

Always use original spare parts.

When contacting our Authorised Service Centre, ensure that you have the following data available: Model, PNC, Serial Number.

The information can be found on the rating plate.

 Warning / Caution-Safety information

 General information and tips

 Environmental information

Subject to change without notice.

1. SAFETY INFORMATION



Before beginning the installation and use of this appliance, carefully read the supplied instructions. The manufacturer is not responsible for any injuries or damage that are the result of incorrect installation or usage. Always keep the instructions in a safe and accessible location for future reference.

1.1 Children and vulnerable people safety

- This appliance can be used by children aged from 8 years and above and persons with reduced physical, sensory or mental capabilities or lack of experience and knowledge if they have been given supervision or instruction concerning the use of the appliance in a safe way and understand the hazards involved.
- Children between 3 and 8 years of age and persons with very extensive and complex disabilities shall be kept away from the appliance unless continuously supervised.
- Children of less than 3 years of age should be kept away from the appliance unless continuously supervised.
- Children should be supervised to ensure that they do not play with the appliance.
- Keep all packaging away from children and dispose of it appropriately.
- Keep detergents away from children.
- Keep children and pets away from the appliance when the door is open.
- If the appliance has a child safety device, it should be activated.
- Children shall not carry out cleaning and user maintenance of the appliance without supervision.

1.2 General Safety

- This appliance is for washing domestic-type, machine-washable laundry only.
- This appliance is designed for single household domestic use in an indoor environment.
- This appliance may be used in, offices, hotel guest rooms, bed & breakfast guest rooms, farm guest houses and other similar accommodation where such use does not exceed (average) domestic usage levels.
- Do not change the specification of this appliance.

- The appliance maximum load is 8.0 kg. Do not exceed the maximum load of each program (refer to the "Programs" chapter).
- The operating water pressure at the water entry point from the outlet connection must be between 0.5 bar (0.05 MPa) and 10 bar (1.0 MPa).
- The ventilation opening in the base must not be covered by a carpet, mat, or any floor covering.
- The appliance must be connected to the water mains using the new supplied hose sets, or other new hose sets supplied by the Authorised Service Centre.
- Old hose sets must not be reused.
- If the mains power supply cable is damaged, it must be replaced by the manufacturer, its Authorised Service Centre or similarly qualified persons to avoid an electrical hazard.
- Before any maintenance operation, deactivate the appliance and disconnect the mains plug from the socket.
- Do not use high pressure water sprays and/or steam to clean the appliance.
- Clean the appliance with a moist cloth. Use only neutral detergents. Do not use abrasive products, abrasive cleaning pads, solvents or metal objects.
- If a tumble dryer is stacked on the top of the washing machine, make sure to use the correct stacking kit approved by AEG (see more details in chapter "Accessories - Stacking kit").

2. SAFETY INSTRUCTIONS

2.1 Installation



The installation must comply with relevant national regulations.

- Remove all the packaging and the transit bolts.
- Keep the transit bolts in a safe place. If the appliance is to be moved in the future they must be reattached to lock the drum to prevent an internal damage.
- Always take care when moving the appliance as it is heavy. Always use safety gloves and enclosed footwear.
- Follow the installation instructions supplied with the appliance.
- Do not install or use a damaged appliance.
- Do not install or use the appliance where the temperature can be less

than 0°C or where it is exposed to the weather.

- The floor area on which the appliance is to be installed must be flat, stable, heat resistant and clean.
- Make sure that there is air circulation between the appliance and the floor.
- Do not install the appliance directly above a floor drain.
- Adjust the feet to have the necessary space between the appliance and the flooring.
- Do not install the appliance where the appliance door cannot be fully opened.
- Do not put a container to collect possible water leakage under the appliance. Contact the Authorised Service Centre to ensure which accessories can be used.

2.2 Electrical connection



WARNING!

Risk of fire and electric shock.

- **WARNING:** This appliance is designed to be installed / connected to a grounding connection in the building.
- Always use a correctly installed shockproof socket.
- Make sure that the parameters on the rating plate are compatible with the electrical ratings of the mains power supply.
- Do not use multi-plug adapters and extension cables.
- Make sure not to cause damage to the mains plug and to the mains cable. Should the mains cable need to be replaced, this must be carried out by our Authorised Service Centre.
- Connect the mains plug to the mains socket only at the end of the installation. Make sure that there is access to the mains plug after the installation.
- Do not touch the mains cable or the mains plug with wet hands.
- Do not pull the mains cable to disconnect the appliance. Always pull the mains plug.

2.3 Water connection

- The inlet water shall not exceed 25 °C.
- Do not cause damage to the water hoses.
- Before connection to new pipes, pipes not used for a long time, where repair work has been carried out or new devices fitted (water meters, etc.), let the water flow until it is clean and clear.
- Ensure that there are no visible water leaks during and after the first use of the appliance.
- Do not use an extension hose if the inlet hose is too short. Contact the Authorised Service Centre for the replacement of the inlet hose.
- When unpacking the appliance, It is possible to see water flowing from the drain hose. This is due to the testing of the appliance with the use of water in the factory.
- You can extend the drain hose to maximum 400 cm. Contact the Authorised Service Centre for the other drain hose and the extension.
- Make sure that there is access to the tap after the installation.

2.4 Use



WARNING!

Risk of injury, electric shock, fire, burns or damage to the appliance.

- Follow the safety instructions on the detergent packaging.
- Do not put flammable products or items that are wet with flammable products in, near or on the appliance.
- Do not wash fabrics which are heavily soiled with oil, grease or other greasy substances. It can damage rubber parts of the washing machine. Prewash such fabrics by hand before loading them into the washing machine.
- Do not touch the glass door while a program operates. The glass can get hot.
- Make sure that all metal objects are removed from the laundry.

2.5 Internal lighting



WARNING!

Risk of injury.

- Visible LED radiation, do not look directly into the beam.
- To replace the internal lighting, contact the Authorised Service Centre.

2.6 Service

- To repair the appliance contact the Authorised Service Centre. Use original spare parts only.
- Please note that self-repair or non-professional repair can have safety consequences and might void the guarantee.
- Concerning the lamp(s) inside this product and spare part lamps sold separately: These lamps are intended to withstand extreme physical conditions in household appliances,

such as temperature, vibration, humidity, or are intended to signal information about the operational status of the appliance. They are not intended to be used in other applications and are not suitable for household room illumination.

2.7 Disposal



WARNING!

Risk of injury or suffocation.

- Disconnect the appliance from the mains electrical and water supplies.
- Cut off the mains electrical cable close to the appliance and dispose of it.
- Remove the door catch to prevent children or pets from becoming trapped in the drum.
- Dispose of the appliance in accordance with local requirements for the disposal of Waste Electrical and Electronic Equipment (WEEE).

3. PRODUCT DESCRIPTION

3.1 Special features

Your new washing machine meets all modern requirements for an effective treatment of laundry with low water, energy and detergent consumption and proper care of fabric.

- The **Wi-Fi connection** and **Remote Start** enable you to start a cycle, to interact with your washing machine and to check the washing cycle status in remote control.
- The **UniversalDose drawer** with a compartment dedicated to each type of detergent, including a compartment for Capsules, equipped with a system able to spread and mixing the detergent in an optimal way, and to dissolve the detergent residues after each cycle.
- The **PowerCare technology** has been designed to protect the fabric fibres thanks to different pre-mixing phases that dissolves first the

detergent and then fabric softener in the water before they are distributed in the laundry. So every fibre is reached and cared for.

- The **ProSense technology** detects the laundry load size defining the program duration in 30 seconds. The washing program is tailored to the laundry load and the type of fabric without consuming more time, energy and water than necessary.
- The steam has a quick and easy way to refresh the clothes. The gentle steam programs remove odours and reduce creases in dry fabrics so they need little ironing.
The **Plus Steam option**, finishes every cycle with gentle steam that relaxes the fibres and reduces fabric creasing. Ironing will be easier!
- The **Stains option** pre-treats stubborn stains optimizing the effectiveness of the stain remover.

3.2 Appliance overview

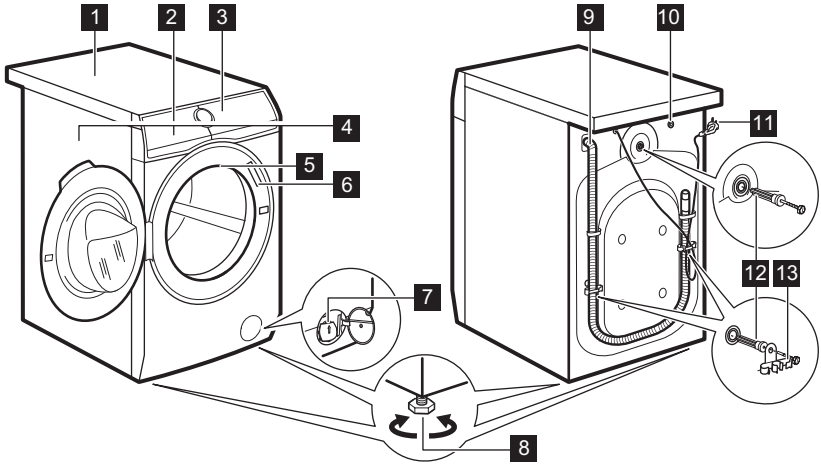

- 1** Worktop
- 2** Detergent dispenser
- 3** Control panel
- 4** Door handle
- 5** Internal light
- 6** Rating plate
- 7** Drain pump filter
- 8** Feet for levelling the appliance
- 9** Drain hose
- 10** Inlet hose connection
- 11** Mains cable
- 12** Transit bolts
- 13** Hose support

The rating plate reports:

- A. QR code
- B. model name
- C. product number
- D. electrical ratings
- E. serial number

4. TECHNICAL DATA

Dimension	Width/ Height/ Total depth	59.7 cm /84.7 cm /57.6 cm
Electrical connection	Voltage	220 - 240 V
	Overall power	2100 W
	Fuse	10 A
	Frequency	50 Hz

Level of protection against ingress of solid particles and moisture ensured by the protective cover, except where the low voltage equipment has no protection against moisture		IPX4
Water supply pressure	Minimum	0.5 bar (0.05 MPa)
	Maximum	10 bar (1.0 MPa)
Water supply ¹⁾		Cold water
Maximum Load	Cotton	8.0 kg
Spin Speed	Maximum spin speed	1400 rpm

¹⁾ Connect the water inlet hose to a water tap with a 3/4" thread.

Power consumption in different modes

Off (W)	Stand-by (W)	Delay start (W)	Networked standby (W)
0.50	0.50	4.00	2.00 ¹⁾

Time to Off/Standby mode is 15 minutes maximum.

¹⁾ The energy consumption of the connected function is approximately 17.5 kWh per year. To disconnect this function, please refer to the chapter 'Wi-fi - Connectivity setup'.

5. INSTALLATION

 **WARNING!**
Refer to Safety chapters.

5.1 Unpacking

 **WARNING!**
Remove all the packaging and the transit bolts before installing the appliance.

 **WARNING!**
Use the gloves.

1. Remove the external film. If necessary, use a cutter.

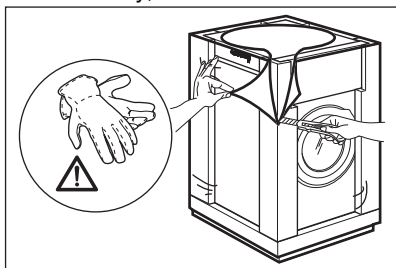

2. Remove the cardboard top and the polystyrene packaging materials.

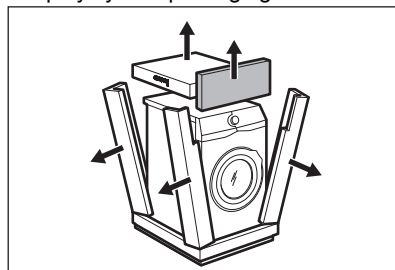

3. Remove the internal film.

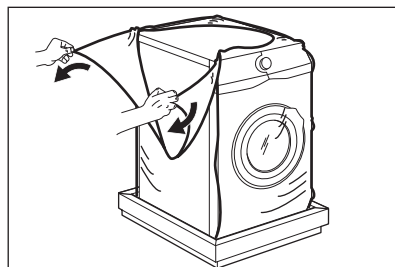

4. Open the door and remove the polystyrene piece from the door seal and all the items from the drum.

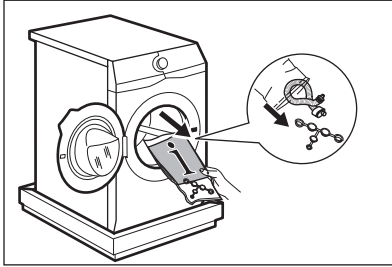

5. Carefully put the appliance down on its rear side.
6. Put the front polystyrene packaging element on the floor under the appliance.

i Make sure not to damage the hoses.

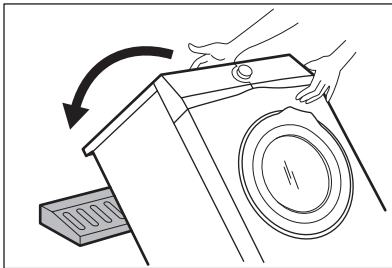

7. Remove the polystyrene protection from the bottom.

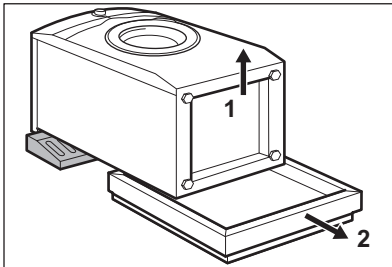

8. Pull up the appliance in vertical position.

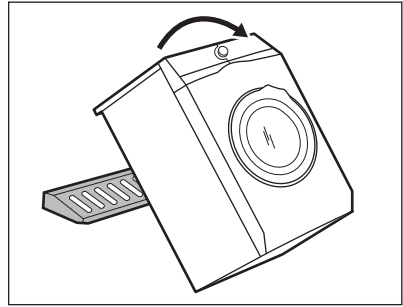

9. Remove the power supply cable and the drain hose from the hose holders.

i It is possible to see water flowing from the drain hose. This is due to the testing with water of the appliance in factory.

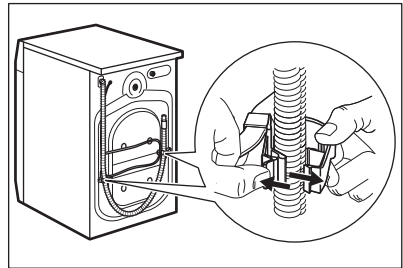

10. Remove the three bolts by using the spanner supplied with the appliance.

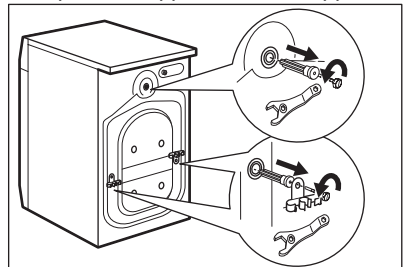

11. Pull out the plastic spacers.
12. Put the plastic caps, that you find in the user manual bag, in the holes.

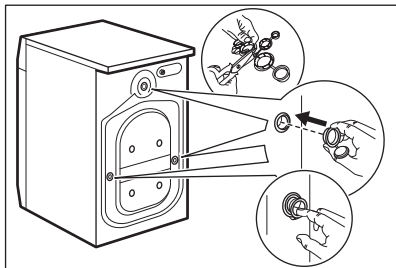

- i** We recommend that you keep the packaging and the transit bolts for any movement of the appliance.

5.2 Positioning and levelling

1. Install the appliance on a flat hard floor.

- i** Make sure that carpets do not stop the air circulation below the appliance. Make sure that the appliance does not touch the wall or other units.

2. Loosen or tighten the feet to adjust the level.



WARNING!

Do not put cardboard, wood or equivalent materials below the appliance feet to adjust the level.

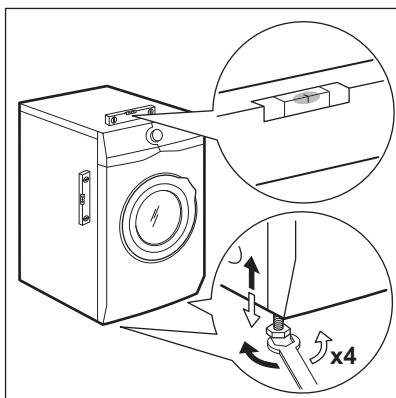

The appliance must be level and stable.



A correct adjustment of the appliance level prevents the vibration, noise and the movement of the appliance when in operation.



When the appliance is installed on a plinth or a tumble dryer is stacked on the washing machine, use the accessories described in chapter 'Accessories'. Read carefully the instructions supplied with the appliance and with the accessory.

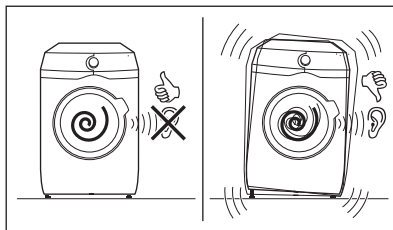

5.3 Fixing plate kit

If you install the appliance on a plinth that is not an accessory supplied by AEG, secure the appliance with the fixing plates. This spare part is available in web shop or from authorised dealer.

Read carefully the instructions supplied with the accessory.

5.4 The inlet hose

1. Connect the water inlet hose to the back of the appliance.
2. Position it toward left or right depending on the position of the water tap.

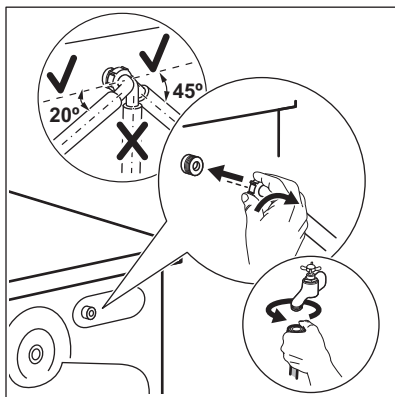

i Make sure that the inlet hose is not in vertical position.

3. If necessary, loose the ring nut to set it in the correct position.
4. Connect the water inlet hose to the cold water tap with 3/4" thread.

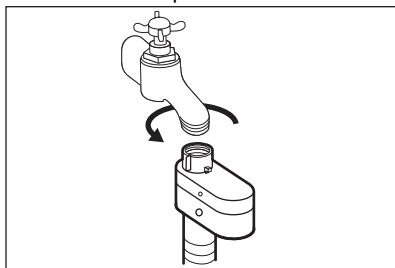

WARNING!
The inlet water shall not exceed 25 °C.



CAUTION!
Make sure that there are no leaks from the couplings.



Do not use an extension hose if the inlet hose is too short. Contact the service centre for the replacement of the inlet hose.

5.5 Water-stop device

The inlet hose has a water stop device. This device prevents water leaks in the hose because of its natural ageing.

The red sector in the window «A» shows this fault.

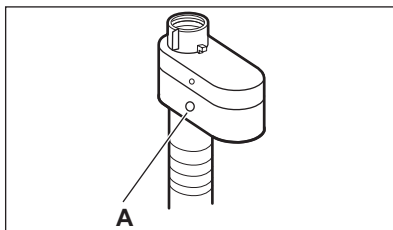

If this occurs, close the water tap and contact the authorized service centre to replace the hose.

5.6 Water drainage

The drain hose should be positioned at a height of not less than 60 cm and not more than 100 cm from the floor.



You can extend the drain hose to maximum 400 cm. Contact the authorized service centre to buy the other drain hose and the extension.

It is possible to connect the drain hose in different ways:

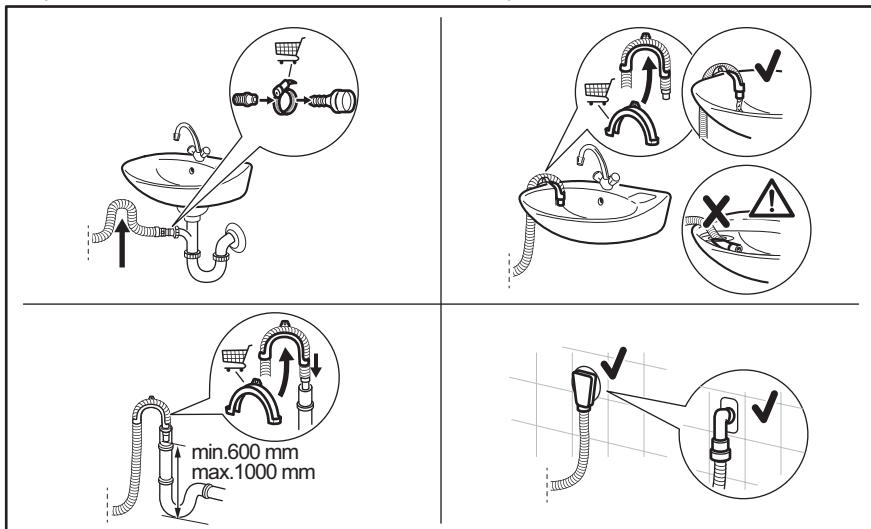

- Connect the drain hose to the spigot and tighten it with a clamp.
- Position the hose directly to a built-in drain pipe in the room wall and tighten it with a clamp.
- Without the plastic hose guide, to a sink spigot - remove the plastic membrane from the sink trap spigot.
- To a stand pipe with vent hole - insert the drain hose directly into a drain pipe or stand pipe.
- The drain hose can be bent into U shape and put around the plastic guide. On the edge of a sink - fasten the guide to the water tap or to the wall.

i Make sure that the drain hose makes a loop to prevent particles going into the appliance from the sink.

i Make sure that the plastic guide cannot move when the appliance drains and the drain hose end is not immersed in the water. There may be a return of dirty water into the appliance. Buy accessories from authorised supplier.

i The end of the drain hose must always be ventilated, i.e. the inner diameter of the drain pipe (min. 38 mm - min. 1.5") must be larger than the external diameter of the drain hose.

5.7 Electrical connection

At the end of installation you can connect the mains plug to the mains socket.

The rating plate and the 'Technical Data' chapter indicate the necessary electrical ratings. Make sure that they are compatible with the mains power supply.

Check that your domestic electrical installation can take the maximum load required, also taking into account any other appliances in use.

Connect the appliance to an earthed socket.

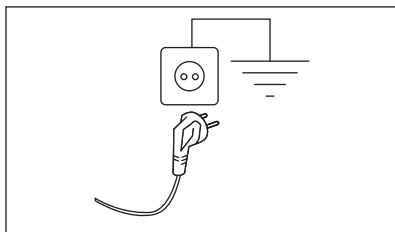

The power supply cable must be easily accessible after installing the appliance.

For any electrical work required to install this appliance, contact our Authorised Service Centre.

The manufacturer does not accept any responsibility for damage or injury through failure to comply with the above safety precaution.

6. CONTROL PANEL

6.1 Control panel description

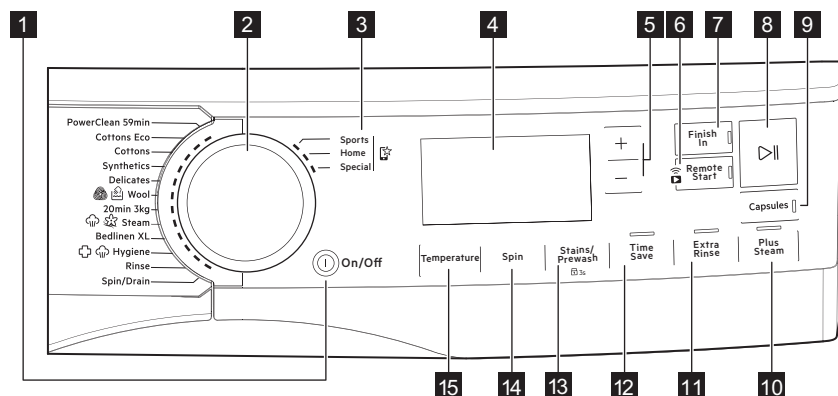









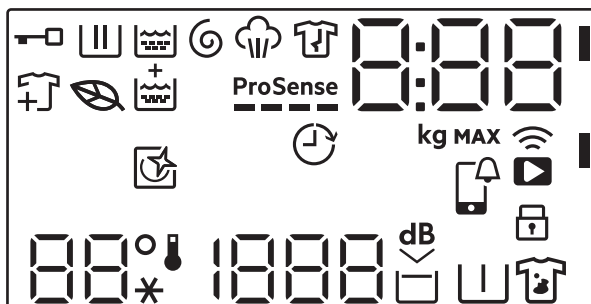



The options are not selectable with all washing programs. Check the compatibility between options and washing programs in the "Options compatibility with programs" paragraph in the "Programs" chapter. An option can exclude another one, in this case the appliance doesn't allow you to set the incompatible options together.











Make sure the screen and touch buttons are always clean and dry.

- | | |
|---|---|
| <p>1 On/Off push button </p> <p>2 Program dial</p> <p>3 Favourite programs </p> <p>4 Display</p> <p>5 Plus (+) and Minus (-) touch buttons linked to Finish In option</p> <p>6 Wi-fi connection and Remote Start touch button </p> <p>7 Finish In touch button</p> | <p>8 Start/Pause touch button </p> <p>9 Capsules touch button</p> <p>10 Plus Steam touch button</p> <p>11 Extra Rinse touch button</p> <p>12 Time Save touch button</p> <p>13 Stains/Prewash touch button and permanent Child Lock option </p> <p>14 Spin touch button</p> <p>15 Temperature touch button</p> |
|---|---|

6.2 Display



	Door locked indicator.
	Washing phase indicator. It flashes during pre-wash and wash phase.
	Rinsing phase indicator. It flashes during rinse phase.
	Spinning and draining phase indicator. It flashes during spin and drain phase.
	Steam phase indicator.
	Anti-crease phase indicator.
	Eco program indicator: it lights on when the selected program and options have an eco profile.
	Add garments indicator: it lights on when the program starts and the user can still pause the appliance and add more laundry.
	Extra Rinse indicator.
	ProSense indicator.
	Finish In indicator.

000	<p>The digital indicator can show:</p> <ul style="list-style-type: none"> • Program duration (e. g. 2:40). <p> The time shown when the program is set could not correspond to effective duration and change after ProSense phase.</p> <ul style="list-style-type: none"> • Maximum load. • Finish in time (e. g. 30' or 2h). • Cycle end (). • Warning code (e.g. E20). • Indication of total operating hours of the appliance. Refer to the 'Operating hours counter' section in the 'Settings' paragraph for more details. • When working with the APP: APP, AP (access point), UPd (update). Please refer to the chapter 'Wi-Fi - Connectivity setup'.
888	<p>Maximum load indicator. The value is shown for three seconds after program selection, alternated with cycle duration.</p>
MAX	<p>Maximum laundry indicator. It blinks if the laundry amount exceeds the declared load.</p>
	<p>This indicator reminds to run a cleaning cycle.</p>
	<p>APP notification to check.</p>
	<p>Remote connection indicator. Wi-Fi connection indicator.</p>
	<p>Child safety lock indicator.</p>
88° --*	<p>The Temperature area: Temperature indicator Cold water indicator</p>
1888 - - -	<p>The spin area: Spin speed indicator No Spin indicator. Spin phase is off.</p>
	<p>Extra Silent indicator.</p>
	<p>Rinse hold indicator.</p>
	<p>Pre-wash indicator.</p>
	<p>Stain indicator.</p>

7. DIAL AND BUTTONS

7.1 On/Off ⓘ

Pressing this button for a few seconds allows to activate or deactivate the appliance. Two different tunes sound while switching the appliance on or off.

As the Stand-by function automatically deactivates the appliance to decrease the energy consumption in a few cases, you may need to activate the appliance again.

For more details, refer to Stand-by paragraph in Daily Use chapter.

7.2 Program dial

By rotating the program dial it is possible to select the desired program.

7.3 Favourite programs ☆

These selector positions are available after the appliance have been connected to Wi-Fi.

The favourite programs can be set and saved via App only choosing from the available ones which are divided into the three categories indicated on the control panel.

Once the favourite programs have been set, you can select one of them via App or by turning the program dial to relevant position: the relevant led comes on and the information on the display are updated accordingly.



The favourite programs can be cancelled through the related App command or pressing the Factory Default key combination.

7.4 Introduction



The options/functions are not selectable with all washing programs. Check the compatibility between options/functions and washing programs in the "Program Chart". An option/function can exclude another one, in this case the appliance doesn't allow you to set the incompatible options/functions together. Make sure the screen and touch buttons are always clean and dry.

7.5 Plus (+) and Minus (-) touch buttons linked to Finish In option

These buttons allow increasing (+) and decreasing (-) the time of cycle end.

7.6 Remote start 📶

A quick touch of this button activates the Remote Start function that allows you to start, pause and stop the appliance remotely.

The related led comes on and the related icon appears on display.



If you set a program via App and it does not match with the knob position,  text appears alternating with program duration.

Press and hold this button for longer time to provide two other functions:

- hold it down for 3 seconds as long as a click sounds: the Wi-Fi is turned on and off.
- hold it down for 10 seconds as long as a double beep sounds and  appears on the display: to reset the Network Credentials.

7.7 Finish In



Set this option as last after program and other options selection, otherwise it can be cancelled if you change some setting.

This button allows activating the Finish In option and by means of the **Plus (+ increases)** and **Minus (- decreases)** touch buttons it is possible to choose the time within which a program should terminate. The program end can be postponed by one 1 hour every + button touch until 24 hours maximum. The 'finish in' time can be reduce by means of the - button until 0.

The display shows the normal program duration alternatively with the set program end time (expressed in hours 0h). The minimum selectable time corresponds to rounded up hour of the maximum duration of a program (e.g. if the cycle duration lasts 3:15 hours, the minimum selectable time will be 4h).

After program start, the door is locked and the appliance starts the ProSense phase. When load estimation ends, on the display the icon of running phase blinks and the time digit counts down in steps of one hour and in steps of 1 minute during the last hour.

7.8 Start/Pause

Touch the Start/Pause  button to start, pause the appliance or interrupt a running program.

7.9 Capsules

Touch this button to activate or deactivate the Capsules option .

When activated the relevant indicator is on.

Follow the Pods manufacturer's dosage and storage recommendations.

Put maximum two tablets or single-dose detergents in the Capsules compartment in the detergent dispenser drawer.

The option remains active also for next cycles until it is deactivated and if it is selectable with the set program.

7.10 Plus Steam

This option adds a steam phase followed by a short anti-crease phase at the end of the washing program.

The steam phase reduces fabric creasing and facilitates the fabric ironing.



The Plus Steam option achieves good results with a small load because steam better penetrates the laundry if there is more space. For this reason, the program maximum load combined with this option is 2 kg (approximately 8 - 10 shirts).



When setting the Plus Steam option, the maximum load drops to 2 kg in the display and program time is adjusted accordingly.

The indicator  blinks in the display during steam phase.



This option can affect the program duration.

When the program stops the display shows a zero , the indicator  is steady on.

The anti-crease phase starts, the indicator  is blinking, and the Start/Pause  led remains lit. The drum performs smooth movements for about 30 minutes to keep the steam benefit.

To interrupt the anti-crease phase, you can:

- Press the On/Off  button for a few seconds to activate or the deactivate the appliance.
- Turning the program dial in another position.

When the anti-crease movements stop and the door unlocks, the appliance proposes again the previous set program.



A small laundry load helps to reach better results.

7.11 Extra Rinse

With this option you can add a few rinses to the selected washing programs and optimise the fabric softener distribution and improve the fabric softness.

It is suggested when you use the fabric softener.

Useful for people allergic to detergents and in areas where the water is soft.

This option increases the program duration.

The button indicator comes on.

7.12 Time Save

With this option you can decrease the program duration.

- If your laundry is normally or lightly soiled, it may be advisable to shorten the washing program. Touch this button **once** to decrease the duration.
- In case of smaller load, touch this button **twice** to set an extra quick program.

In this case, the temperature 95°C is not selectable.

The led of the button is on and the display shows the set program duration.

- This option can also be used to shorten the steam program duration.

7.13 Stains/Prewash

Press this button repeatedly to activate one of the two options.

The relevant indicator goes on in the display.

- **Stains**
Select this option to pre-treat heavily soiled or stained laundry using stain remover.
Pour the stain remover into compartment . The stain remover is pre-mixed and heated with detergent in order to improve its effectiveness.

- This option is not available with a temperature lower than 40 °C.

• Prewash

Use this option to add a prewash phase at 30 °C before the washing phase.

This option is recommended for heavily soiled laundry, especially if containing sand, dust, mud and other solid particles.

- The options can increase the program duration.

- These two options cannot be set together.

7.14 Spin

When you set a program, the appliance automatically selects the default spin speed.

Touch this button repeatedly to:

- **Change the spin speed.**

- The display shows only the spin speeds available for the set program.

- **Activate the Rinse Hold option .**

The water of the last rinse is not drained out to prevent the fabrics from creasing. The washing program ends with water in the drum and the final spin phase is not performed.

The display shows the indicator . The drum turns regularly to reduce creasing.

The door stays locked. The drum turns regularly to reduce creasing. You must drain the water to unlock the door.

Touch Start/Pause button : the appliance performs the spinning phase and drains the water.

- **Activate the Extra silent option.**
All spinning phases (intermediate spin and final spin) are suppressed and the program ends with water in the drum. This helps to reduce creasing. As the program is very quiet, it is suitable for use at night time when cheaper electricity tariffs are available. In some programs the rinses are performed with more water.

The display shows the indicator . The door stays locked. The drum turns regularly to reduce creasing.

You must drain the water to unlock the door.
Touch the Start/Pause button: the appliance performs only the draining phase.

- **No Spin – – –.**
Set this option to deactivate all spin phases. The display shows the indicator – – –. The appliance performs the only draining phase of the selected washing program. Set this option for very delicate fabrics. The rinses phase uses more water for some washing programs

 The appliance empties the water out automatically after approximately 18 hours.

8. SETTINGS

8.1 Introduction

 When pressing a key combination, **do not tilt** your fingers downwards. The sensors of the underneath buttons are sensitive and may interfere with Your choice.

8.2 Acoustic signals

This appliance is provided with different acoustic signals, that operate when:

- You activate the appliance (special short tune).
- You deactivate the appliance (special short tune).
- You touch the buttons (click sound).
- You make a wrong selection (3 short sounds).
- The program is completed (sequence of sounds for about 2 minutes).
- The appliance has a malfunction (sequence of short sounds for about 5 minutes).
- When a laundry overload is detected during ProSense phase (a double sound played one).

To **activate/deactivate** this option, hold down the Extra Rinse button until a beep or a double beep sounds.

7.15 Temperature

When you select a washing program, the appliance automatically proposes a default temperature.

Touch this button repeatedly until the desired temperature value appears on the display.

When the display shows the indicators  and – –, the appliance does not heat the water.

 If you deactivate this function, the acoustic signals stops playing at the end of the program only.

8.3 Child Lock

With this option you can prevent children from playing with the control panel.

To **activate/deactivate** this option, hold down the Stains/Prewash button until  **comes on/goes off** on the display.

The appliance will default to this option after you switch it off.

8.4 Operating Hours Counter

It is possible to visualise the total operating time of the appliance in hours, starting from the first switching on. This value will count operating time of the cycles (does not include pauses, delayed start time). To visualise this value, proceed as follows:

1. Switch the appliance on by pressing the On/Off  button.
2. Press and hold the Extra Rinse and Plus Steam buttons for some seconds.
3. After 3 seconds the total hours operated by the appliance are shown in the display: e.g. 1276 hours, the

display shows the text Hr for 2 seconds, 12 (thousands and hundreds) for 2 seconds and 76 (tens and units).

- To exit this mode, press any button or switch the appliance off by means of the On/Off  button.

 If the procedure does not work (due to timeout or wrong keys combination), switch the appliance off and repeat sequence from the beginning.

9. BEFORE FIRST USE

 During installation or before first use you may observe some water in the appliance. This is a residual water left in the appliance after a full functional test in the factory to ensure the appliance is delivered to customers in perfect working order and is no cause for concern.

- Make sure that all transit bolts have been removed from the appliance.
- Make sure that the electrical power is available and the water tap is open.

10. PROGRAMS

10.1 AEG App app and additional hidden programs

AEG App app provides you with a **wide choice of additional hidden programs**. Connect the appliance to AEG App and you will be able to choose the program that suits your needs most.

You can also memorize any of the hidden cycles in the favourite program  positions. To select the program from the appliance directly refer to the "Favourite programs" paragraph in "Dial and buttons" chapter.



 Program names are subject to change depending on market requirements without notice.

In the App you can find a complete description of each program.

8.5 Factory Defaults

This function allows to restore the factory default options. To **activate** this option follow steps below:

- Switch the appliance on by pressing On/Off  button.
- Press and hold the Stains/Prewash and Time Save buttons for some seconds.
- The display will show - - - for about 5 seconds.

- Remove the folded tag in the detergent compartment marked by . This tag suggests to use the right amount of detergent or softener for avoiding overdosing.
- Pour 2 litres of water into the detergent compartment marked by .

This action activates the drain system.

- Set and start a program for cotton at the highest temperature without any detergent and laundry in the drum.

Sportswear	Bed Linen	Denim	Machine Clean
Daily Training	Curtains	Silk	1 Item Fast
Down Jackets	Pillow	Baby	Anti-Allergy Vapour
Soccer/Rugby	Towels	Linen	Easy Iron
Skiing Gear	Duvet	Business Shirts	
Running Shoes	Pet Hair	Steam Cashmere	
Outdoor			



10.2 Program Chart



The programs are described in this chart following the order of the selector dial from the top to the bottom.

Washing programs

Program	Program description
PowerClean 59min	Cotton and mixed synthetic fabrics. Ideal to wash your daily load in a short time, for a better clothes care and good cleaning already at 30°C.
Cottons Eco	White cotton and coloured cotton. Normally, heavily and lightly soiled items. The Cottons Eco program at 40 °C is recommended for a normally soiled full load of cotton and is the water and energy rating label program in accordance with AS/NZS2040 and AS/NZS6400.
Cottons	White and coloured cotton fabrics. Ideal for normal and heavy soil.
Synthetics	Synthetic items or mixed fabric items. Normal soil.
Delicates	Delicate fabrics such as acrylics, viscose and mixed fabrics requiring gentler washing. Normal soil.
 Wool	Machine washable wool, hand washable wool and other fabrics with «hand washing» care symbol ¹⁾ .
20min 3kg	Cotton and synthetic items lightly soiled or worn only once.



Program	Program description
 Steam	<p>Cotton, synthetic and mixed items. Special steam cycle without washing that can be used to prepare your dried laundry for ironing or refreshing garments worn once. This program reduces creases, odours and relaxes the fibres. Do not use any detergent.</p> <p>When the program is completed, quickly remove the laundry from the drum²⁾. If necessary, remove stains by washing or using localized stain removal. Steam programs do not perform any hygienic cycle. Do not set a Steam program with these types of items:</p> <ul style="list-style-type: none"> • Items that are not suitable for tumble drying. • Items with label "Dry clean only".
Bedlinen XL	<p>Specific cycle developed for bed linen items (up to three bedlinen sets, one of which can be double size). Temperature settings and washing cycle duration are selected to obtain good washing performance in your daily cycles.</p>
 Hygiene	<p>White cotton items. This high-performance wash program combined with steam vapour, removes more than 99,99% of bacteria and viruses³⁾ keeping the temperature above 60°C throughout the washing phase; with an additional action on the fibers thanks to a vapour phase, an enhanced rinsing phase ensures a proper removal of detergent and micro-organism residues. This program ensures also a proper reduction of pollens/allergenic items.</p>
Rinse	<p>All fabrics, except woollens and very delicate fabrics. Program for rinsing and spinning the laundry. The default spin speed is the one used for cotton programs. Reduce the spin speed accordingly to the type of laundry. If necessary, set the Extra Rinse option to add rinses. With a low spin speed the appliance performs delicate rinses and a short spin.</p>
Spin/Drain	<p>To spin the laundry and to drain the water in the drum. All fabrics, except woollens and delicate fabrics.</p>

1) During this cycle the drum rotates slowly to ensure a gentle wash. It can seem that the drum doesn't rotate or doesn't rotate properly, but this is normal for this program.

2) If you set a Steam program with dried laundry, at the end of the cycle the laundry can be humid. Line dry the items for about 10 minutes. This program does not remove particularly intense odour.

3) Tested for Staphylococcus aureus, Enterococcus faecium, Candida albicans, Pseudomonas aeruginosa and MS2 Bacteriophage in external test performed by Swisstat Testmaterialien AG in 2021 (Test Report No. 202120117).

Program temperature, maximum spin speed and maximum load

Program	Default temperature Temperature range	Reference spin speed Spin speed range	Maximum load
PowerClean 59min	30 °C 60 °C - 30 °C	1400 rpm 1400 rpm - 400 rpm	5.0 kg
Cotton Eco ¹⁾	40 °C 60 °C - 40 °C	1400 rpm 1400 rpm - 400 rpm	8.0 kg
Cottons	40 °C 95 °C - Cold	1400 rpm 1400 rpm - 400 rpm	8.0 kg
Synthetics	40 °C 60 °C - Cold	1200 rpm 1200 rpm - 400 rpm	3.0 kg
Delicates	30 °C 40 °C - Cold	800 rpm 1200 rpm - 400 rpm	2.0 kg
 Wool	40 °C 40 °C - Cold	1200 rpm 1200 rpm - 400 rpm	2.0 kg
20min 3kg	30 °C 40 °C - 30 °C	1200 rpm 1400 rpm - 400 rpm	3.0 kg
 Steam	-	-	1.0 kg
Bedlinin XL	30 °C 60 °C - Cold	1200 rpm 1200 rpm - 400 rpm	4.5 kg
 Hygiene	60 °C	1400 rpm 1400 rpm - 400 rpm	8.0 kg
Rinse	-	1400 rpm 1400 rpm - 400 rpm	8.0 kg
Spin/Drain	-	1400 rpm 1400 rpm - 400 rpm	8.0 kg



¹⁾ The cotton program at 40 °C with the **ECO** option is recommended for a full load of normally soiled cotton and is the water and energy rating label program in accordance with AS/NZS2040.2 and AS/NZS6400.

10.3 Steam programs

The Steam programs can be used for reducing wrinkles and odours on garments (such as cottons, synthetics, mixed fabrics, including delicates) that just need to be refreshed, in a short time, avoiding washing.

The fabric fibres are relaxed and afterwards ironing becomes effortless. When the cycle is completed, quickly remove the laundry from the drum.

The cycle duration can be reduced till 15 minutes by means of the Time Save option.

	PowerClean 59min	Cotton Eco	Cottons	Synthetics	Delicates	Wool	20min 3kg	Steam	Bedlinen XL	Hygiene	Rinse	Spin/Drain
 Stains ²⁾		■	■	■						■		
 Prewash		■	■	■								
Time Save ³⁾		■	■	■				■	■			
Extra Rinse	■	■	■	■	■				■	■	■	
Plus Steam ²⁾	■	■	■	■					■	■		
Capsules	■	■	■	■	■		■		■	■		
Finish In	■	■	■	■	■	■	■	■	■	■	■	■

¹⁾ If you set the No Spin option, the appliance performs draining only.

²⁾ This option is not available with temperature lower than 40 °C.

³⁾ If you set the shortest duration, we recommend that you decrease the load size. It is possible to fully load the appliance, however the washing results can be less satisfactory.

Suitable detergents for washing programs

Program	Universal powder ¹⁾	Liquid Universal	Liquid for coloureds	Delicates woollens	Special
PowerClean 59min	--	▲	▲	--	--
Cottons Eco	▲	▲	▲	--	--
Cottons	▲	▲	▲	--	--
Synthetics	▲	▲	▲	--	--
Delicates	--	--	--	▲	▲
Wool	--	--	--	▲	▲
20min 3kg	--	▲	▲	--	--
Bedlinen XL	--	--	--	▲	▲
Hygiene	▲	▲	--	--	▲

¹⁾ At temperature higher than 60 °C the use of powder detergent is recommended.

▲ = Recommended

-- = Not recommended

11. 📶 WI-FI - CONNECTIVITY SETUP

This chapter describes how to connect the smart appliance to the Wi-Fi network and to link it to mobile devices.

By this functionality you can receive notifications, control and monitor your appliance from your mobile devices.

The Wi-Fi functionality is off as factory default setting.

To connect the appliance to enjoy the full range of features and services you need:

- Wireless network at home with internet connection enabled.
- Mobile device connected to wireless network.

Frequency	2.4 GHz according to local country regulation
Protocol	IEEE 802.11b/g/n
Max power	According to local country regulation



Minimum requirements:
Operating system compatibility iOS 15/Android 7.1 and above. Install the AEG App, create an account and accept the Terms and Conditions and AEG Privacy Policy to use the connected features. Stable Internet and good Wi-Fi connection with 2.4GHz wireless frequency is required. Minimum requirements, apps and services are subject to change without notice.

11.1 QR code on rating plate

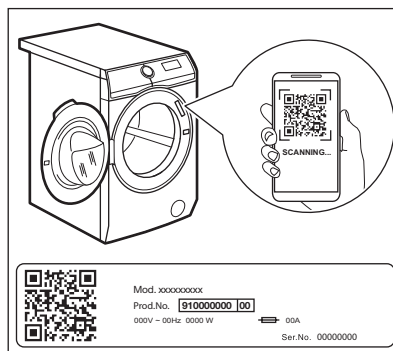

QR code can be used in two ways:

- Scan the QR code with the built-in camera app to register your product.
- Pairing your smart device with appliance to simplify the process. Scan the QR code with QR code scanner built-in AEG App application.

11.2 Installing and configuring AEG App





AEG App allows you to control your laundry through a mobile device. It contains a large number of programs, useful features and product information tailored perfectly to the appliance. Through the app you can select the programs already available from the appliance control panel, plus unlock additional programs available only from a mobile device. Additional programs can change over the time along with new versions of the app. It's personalized laundry care - all from your mobile device.

When connecting the appliance to the application, stand near it with your mobile device.

Make sure that your mobile device is connected to the wireless network.

1. Go to the App Store on your smart device or scan QR code (*see 'QR code on rating plate' paragraph*).
2. Download and install the AEG App.
3. Make sure you started a Wi-fi connection in the appliance. If not, read the next paragraph 'Configuring the appliance wireless connection'.
4. Start the application. Select the country and language and login with Your email and password. If you do not have an account, create a new one following the instructions in AEG App.
5. Follow the instructions on the App for the appliance registration and configuration.

11.3 Configuring the appliance wireless connection

1. Press the On/Off  button for a few seconds to activate the appliance. Wait about 10 seconds before proceeding with wireless configuration.
2. Select a program by turning the program dial.
3. Press and hold the Remote Start  button for a few seconds until a 'click' sounds. Release the button. *On* appears on the display for 5 seconds and the indicator  starts blinking. The wireless module begins starting up.



-  Make sure that you APP is ready for connection.

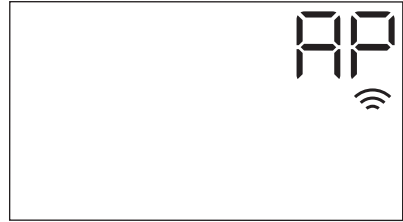

4. After about 10 seconds, **AP** (**Access Point**) appears on the display.





The access point will be open for about 3 minutes.

5. Configure the AEG App app on your smart device and follow the instructions to connect the appliance to your Wi-Fi network.
6. If the connectivity is configured, when the program information screen returns, the indicator  is on the display.



-  Every time you switch the appliance on, the appliance takes about 10 seconds to connect to the network automatically. When the indicator  stops blinking the connection is ready.

To switch the wireless connection off, press and hold the Remote Start  button for a few seconds until the first acoustic signal. Release the button. *OFF* appears on the display for 5 seconds.



-  If you switch the appliance off and on again, the wireless connection is automatically off.

To remove the wireless credentials, press and hold the Remote Start  button for a few seconds until the second



acoustic signal:  appears on the display for a few seconds.

11.4 Remote Start



The Remote Start enables you to start a cycle in remote control.



-  The Remote Control activates automatically when you press the Start/Pause  button to start the program, but it is also possible to start a washing program remotely. This function is deactivated when door is open.



When the App is installed and the wireless connection is complete, you can activate the Remote Start:



1. Touch the Remote Start  button and the indicator  blinks on the display for a few seconds.



2. Touch the Start/Pause  button to activate the Remote Start before the indicator  stops blinking.

The indicators  and  appear on the program summary screen and the door is locked. Now it is possible to start the program remotely.

-  When touching the Start/Pause  button after the indicator  stops blinking, the Remote Start is not activated, but the set program starts.

To remove the Remote Start, tap on the Remote Start  button and confirm by pressing the Start/Pause  button.

11.5 Over-the-air update

The App may propose an update for your appliance.

The update is accepted via App only.

If a program is running, the App notifies that the update will start at the end of the program.

During the update, the appliance shows  in the display.

Do not switch off or unplug the appliance during update.

The appliance will be usable again at the end of the update, without any notification about successful update.

If an error occurs, the appliance shows  in the display: just press any buttons or turn the knob to return to normal use.

11.6 Wi-Fi Always On

The Wi-Fi Always On function is available in the App.

This function keeps the appliance connected to the network even when the appliance is turned off.

The indicator  goes on and off intermittently (1 second on , 5 seconds off).

It is possible to turn the appliance on by pressing the On/Off  button or through the App.

-  The Wi-Fi Always On function may affect your energy consumption.

12. DAILY USE



WARNING!
Refer to Safety chapters.

12.1 Activating the appliance

1. Connect the mains plug to the mains socket.
2. Open the water tap.
3. Press the On/Off  button for a few seconds to activate the appliance.

A short tune sounds. The appliance automatically proposes a default program. The relevant indicator illuminates.

The display shows the cycle duration, the maximum load (for a few seconds), the default temperature, the default spin speed and the indicators of the phases making up the program.

12.2 Loading the laundry

1. Open the appliance door.
2. Shake the items before you put them in the appliance.
3. Put the laundry in the drum, one item at a time.

Make sure not to put too much laundry in the drum.

4. Close the door firmly.

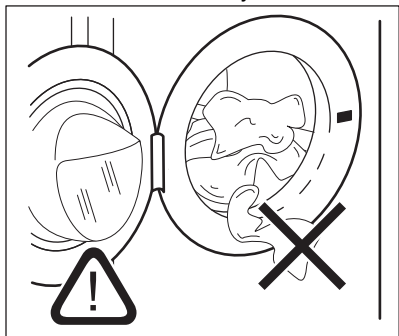

CAUTION!

Make sure that no laundry stays between the seal and the door. There is a risk of water leakage or damage to the laundry.



CAUTION!

Washing heavily oiled, greasy stains could cause damage rubber parts of the washing machine.

12.3 Filling the detergent and additives

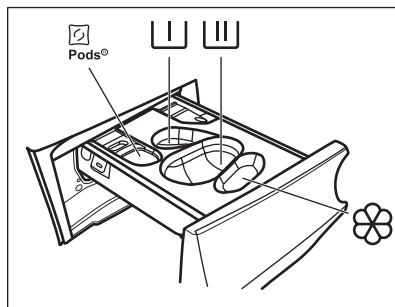

- Compartment for detergent pods (Max 2 pods). When using detergent tablets, make sure that the Pods® option is activated.



- Compartment for prewash phase an soak program (powder detergent only).



- Compartment for washing phase (powder detergent only).



Make sure that the Pods® option is deactivated when using this compartment.



If using liquid detergent, remember to insert the container for liquid detergent



- Compartment for fabric softener and other liquid treatments (fabric conditioner, starch).



MAX - Always follow the instructions that you find on the packaging of the detergent products, but we recommend that you do not exceed the maximum indicated level (**MAX**). This quantity will however guarantee the best washing results.

- i** After a washing cycle, if necessary, remove any detergent residue from the detergent dispenser.

Proceed as follows

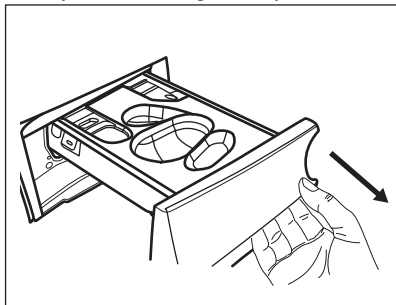
1. Open the detergent dispenser.



2. If a prewash phase is set, put the powder detergent in compartment .
3. For main wash, chose the proper compartment depending on the type of detergent:
 - a) Put the **powder detergent** in the compartment .

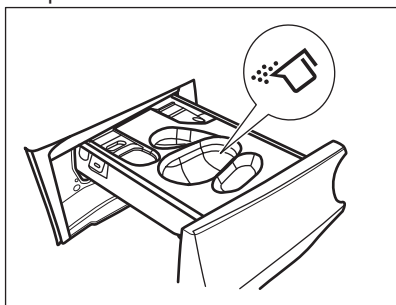

- b) Pour the **liquid detergent** in the same compartment after inserting the relevant container .

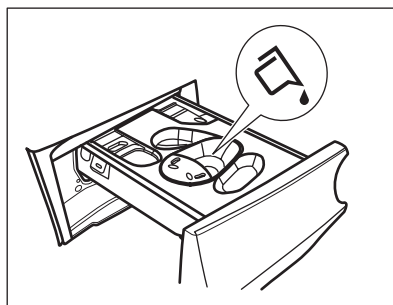
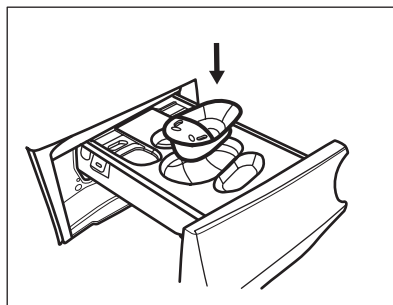

- c) Put the **tablets** in the compartment . Make sure that the Pods® option is activated.

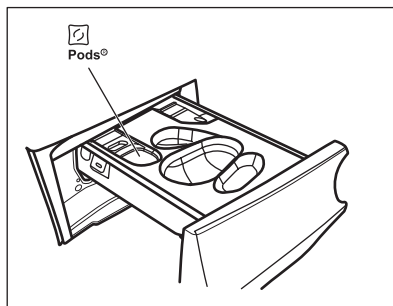

4. Pour fabric softener in the compartment .
5. Close the detergent dispenser.

12.4 Setting a program

1. Turn the program dial to select the desired washing program. The related program indicator comes on.

The indicator of the Start/Pause  button flashes.

The display shows an indicative program duration, the maximum declared load for the set program (only for a few seconds),

the default temperature, the default spin speed and the washing phase indicators (when available).

2. To change the temperature and/or the spin speed, touch the related buttons.
3. If desired, set one or more options by touching the related buttons. The related indicators come on in the display and the given information changes accordingly.

 In case a selection is **not possible**, no indicator comes on and an acoustic signal sounds.

12.5 Starting a program

Touch the Start/Pause  button to start the program.

The related indicator stops flashing and stays on.



In the display, the indicator of the operating phase starts flashing.

The program starts, the door is locked.

The display shows the indicator .

 The drain pump can operate shortly before the appliance fills water.

12.6 Starting a program with the Finish In option

1. Touch this repeatedly until the display shows the desired time within the program should end. The indicator  comes on.
2. Touch the Start/Pause  button. The drum starts rotating to perform the ProSense estimation, if foreseen in the selected program.
3. The appliance starts the countdown to the end of the program and the program will start at the right moment for ending at the time set through this option.

To change or cancel this option:

1. Switch the appliance off by means of the On/Off  button.
2. Switch the appliance on again.



3. Set the program again.



12.7 The ProSense load detection

 The program duration in the display is referred to a **medium/high load**.

After setting a washing program, the **ProSense**  icon lights up on the display if the program supports it.

After touching the Start/Pause  button, the ProSense starts the laundry load detection:

1. The appliance detects the load in the first 30 seconds: the indicator  flashes, the bars under the **ProSense**  icon move back and forth and the drum rotates shortly.
2. When the drum stops rotating, the display shows the new program duration, that could increase or decrease, adjusted accordingly the load detected, the number of bars indicates the load in quarter (from 1 to 4, 4 bars in case of overload), the maximum declared load indicator comes on again. After further 30 seconds, the water filling starts.

 In case of **in case of drum overload**, the maximum declared load indicator comes on again with the **MAX** indicator blinking. In this case, during these 30 seconds, it is possible to pause the appliance and remove the exceeding garments. Once removed the exceeding garments, touch the Start/Pause  button to start the program again. The ProSense phase can be repeated up to three times (see point 1).

Important! If the laundry amount will not be reduced, the washing program starts

anyway, despite the overload. In this case, it will be not possible to guarantee the best washing results.

 About 20 minutes after the program start, the program duration could be adjusted again depending on the capacity of water absorption of the fabrics.

 The ProSense detection is carried out with complete washing programs only (no skipping phase selected).

 The ProSense is not available with some programs, such as Wool, programs with short cycles and without washing phase.

12.8 Program phase indicators

When the program starts the indicator of the running phase flashes and the other phase indicators are steady on.

E.g. the washing or pre wash phase is

running: 

When the phase ends the relevant indicator stops flashing and is steady on. The next phase indicator starts flashing.

E.g. the rinse phase is running: 

If you select the Plus Steam the steam phase indicators come on.

The steam phase is running: 

The anti-crease phase is running:



12.9 Interrupting a program and changing the options

When the program is running, you can change **only some** options:

1. Touch the Start/Pause  button. The related indicator flashes.

2. Change the options. The given information in the display changes accordingly.

3. Touch the Start/Pause  button again.

The washing program continues.

12.10 Cancelling a running program

1. Press the On/Off  button to cancel the program and to deactivate the appliance.

2. Press the On/Off  button again to activate the appliance.

Now, you can set a new washing program.

 If the ProSense phase is already carried out and the water filling is already started, the new program starts **without repeating the ProSense phase**. The water and the detergent are not drained out in order to avoid waste. The display shows the maximum duration of the program, updating it about 20 minutes after the starting of the new program.

12.11 Opening the door - Adding garments

While a program or the delay start operates, the appliance door is locked.

 If the temperature and level of the water in the drum are too high and/or the drum still rotates you cannot open the door.



You can easily open the door for adding or removing some items when the icon  is lighted on.

1. Touch the Start/Pause  button.

In the display the related door lock indicator goes off.

2. Open the appliance door. If necessary, add or remove the items.

3. Close the door and touch the Start/Pause  button.

The program or the delay start continues. When the icon  goes off, the door can be opened when the program is complete. You may also set a spinning or draining program/option and then press Start/Pause  button. If the spin and drain programs are not available in the program dial, they can be set via App.

12.12 End of the program

When the program has finished, the appliance stops automatically. The acoustic signals operate (if they are active).

In the display all washing phase indicators become steady and the time area shows .

The indicator of the Start/Pause  button goes off.

The door unlocks and the indicator  goes off.



1. Press the On/Off  button to deactivate the appliance. After five minutes from the end of the program, the energy saving function automatically deactivates the appliance.



 When you activate the appliance again, the display shows the end of the last selected program. Turn the program dial to set a new cycle.









2. Remove the laundry from the appliance.
3. Make sure that the drum is empty.
4. Keep the door and the detergent dispenser slightly ajar to prevent mildew and odours.
5. Close the water tap.

12.13 Draining water out after end of cycle

If you have chosen a program or an option that does not empty out the water of the last rinse, the program is completed, but:

- The display shows the indicator , the option indicator  or  and the



door locked indicator . The indicator of the running phase  flashes.

- The drum still turns at regular intervals to prevent the creases in the laundry.
 - The door stays locked.
 - You must drain the water to open the door:
1. If necessary, touch the Spin button to decrease the spin speed proposed by the appliance.
 2. Touch the Start/Pause  button:
 - If you have set , the appliance drains the water and spins.
 - If you have set , the appliance only drains the water.
- The option indicator  or  goes off, while the indicator  flashes and then goes off.
3. When the program is completed and the door locked indicator  goes off, you can open the door.
 4. Press the On/Off  button a few seconds to deactivate the appliance.

 In any case, the appliance empties the water out automatically after approximately 18 hours.

12.14 Stand-by option

The Stand-by function automatically deactivates the appliance to decrease the energy consumption when:

- You do not use the appliance for 5 minutes before you touch the Start/Pause  button. Press the On/Off  button to activate the appliance again.
- After 5 minutes from the end of the washing program Press the On/Off  button to activate the appliance again. The display shows the end of the last set program. Turn the program dial to set a new cycle.

- i** If you set a program or an option that ends with water in the drum, the Stand-by function **doesn't deactivate** the appliance to remind you to drain the water.

- i** If the Wi-Fi Always On function is active, only the indicator  goes on and off intermittently.

13. HINTS AND TIPS

- !** **WARNING!**
Refer to Safety chapters.

13.1 The laundry load

- Divide the laundry into: white, coloured, synthetics, delicates and wool.
- Follow the washing instructions on the laundry care labels.
- Do not wash white and coloured items together.
- Some coloured items can discolour with the first wash. We recommend that you wash them separately for the first couple of times.
- Turn multilayered fabrics, wool and items with printed illustrations inside out.
- Pre-treat stubborn stains.
- Wash stubborn stains with a special detergent.
- Be careful with curtains. Remove the hooks and put the curtains in a washing bag or pillowcase.
- A very small load can cause balance problems with the spin phase leading to excessive vibration. If this occurs:
 - a. interrupt the program and open the door (refer to "Daily Use" chapter);
 - b. manually redistribute the load so that the items are spaced evenly around the tub;
 - c. press the Start/Pause button. The spin phase continues.
- Button up pillowcases, close zippers, hooks and poppers. Tie up belts, cords, shoelaces, ribbons and any other loose elements.
- Do not wash laundry without hems or with cuts. Use a washing bag to wash small and/or delicate items (e.g. underwired bras, belts, tights, shoelaces, ribbons, etc.).

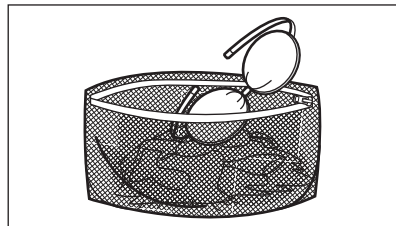

- Empty pockets and unfold the items.

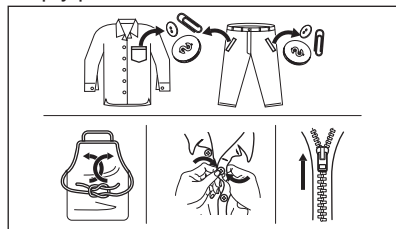

13.2 Stubborn stains

For some stains, water and detergent is not sufficient.

We recommend that you pre-treat these stains before you put the items in the appliance.

Special stain removers are available. Use the special stain remover that is applicable to the type of stain and fabric.

Do not spray stain remover on garments near the appliance as it is corrosive to the plastic parts.



13.3 Detergent type and quantity

The choice of detergent and use of correct quantities not only affects your wash performance, but also helps to avoid waste and protect the environment:

- Use only detergents and other treatments specially made for washing machines. First, follow these generic rules:
 - powder detergents (also tablets and single-dose detergents) for all types of fabric, excluding delicate. Prefer powder detergents containing bleach for whites and laundry sanitization,
 - liquid detergents (also single-dose detergents) , preferably for low temperature wash programs (60 °C max) for all types of fabric, or special ones for woollens only.
- The choice and quantity of detergent will depend on: type of fabric (delicates, woollens, cottons, etc), the colour of clothes, size of the load, degree of soiling, wash temperature and hardness of the water used.
- Follow the instructions that you find on packaging of the detergents or other treatments without exceeding the indicated maximum level (**MAX**).
- Do not mix different types of detergents.
- Use less detergent if:
 - you are washing a small load,
 - the laundry is lightly soiled,
 - there is large amounts of foam during washing.

Insufficient detergent may cause:

- unsatisfactory washing results,
- the wash load to turn grey,
- greasy clothes,

- mould in the appliance.

Excessive detergent may cause:

- sudsing,
- reduced washing effect,
- inadequate rinsing,
- a greater impact for the environment.

13.4 Ecological hints

To save water, energy and to help protect the environment, we recommend that you follow these tips:

- **Normally soiled laundry** may be washed **without prewash** in order to save detergent, water and time (the environment is protected too!).
- Loading the appliance to the **maximum capacity indicated for each programs helps to reduce energy and water consumption.**
- With adequate pre-treatment, stains and limited soiling can be removed; the laundry can then be washed at a lower temperature.
- Set the **maximum possible spin speed** for the selected washing program **before drying your laundry in a tumble dryer.** This will save energy during drying!

13.5 Water hardness

If the water hardness in your area is high or moderate, we recommend that you use a water softener for washing machines. In areas where the water hardness is soft it is not necessary to use a water softener.

To find out the water hardness in your area, contact your local water authority.

Use the correct quantity of water softener. Follow the instructions that you find on the packaging of the product.

14. CARE AND CLEANING



WARNING!

Refer to Safety chapters.

14.1 Periodic cleaning schedule

Periodic cleaning helps to extend the life of your appliance.

After each cycle, keep the door and the detergent dispenser slightly ajar to get air circulation and dry the humidity inside the appliance: this will prevent mildew and odours.

If the appliance is not used for a long time: close the water tap and unplug the appliance.

Indicative periodic cleaning schedule:

Descaling	Twice a year
Maintenance wash	Once a month
Clean door seal	Every two months
Clean drum	Every two months
Clean detergent dispenser	Every two months
Clean drain pump filter	Twice a year
Clean the inlet hose and the valve filter	Twice a year

The following paragraphs explain how you should clean each part.

14.2 Removing foreign objects

-  Make sure that pockets are empty and all loose elements are tied up before running your cycle. Refer to "The laundry load" in "Hints and tips".

Remove any foreign objects (such as metal clip, buttons, coins, etc) that you may find in the door seal, the filters and the drum. Refer to "Door seal with double lip trap", "Cleaning the drum", "Cleaning the drain pump" and "Cleaning the inlet hose and the valve filter" paragraphs. If necessary, please contact the Authorised Service Centre.

14.3 External cleaning

Clean the appliance with mild soap and warm water only. Fully dry all the surfaces.

Do not use a scouring pads or any scratching material.



CAUTION!

Do not use alcohol, solvents or chemical products.



CAUTION!

Do not clean the metal surfaces with chlorine-based detergent.

14.4 Descaling



If the water hardness in your area is high or moderate, we recommend that you use a water descaling product for washing machines.

Regularly examine the drum to check for limescale.

The regular detergents already contain water softening agents, but we recommend to run a cycle with empty drum and a descaling product occasionally.



Always follow the instructions that you find on the packaging of the product.

14.5 Maintenance wash

The repeated and prolonged use of low temperature and short programs can cause detergent deposits, fluff residues, bacterial growth and biofilm formation inside the drum and the tub. This could generate bad odours and mildew.

To eliminate these deposits and hygienize the inner part of the appliance, run a maintenance wash at least once a month:

1. Remove all laundry from the drum.
2. Run a cotton program with the highest temperature without detergent.

14.6 Door seal

This appliance is designed with a **self cleaning draining system**, allowing light fluff fibers that fall off the clothes to be drained out with the water. Regularly examine the seal. Coins, buttons, other small items can be recovered at the end of the cycle.

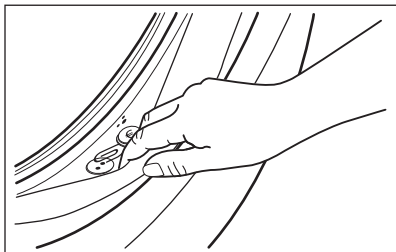

Clean it when needed, using ammonia cream cleanser agent without scratching the seal surface.

- i** Always obey the instructions that you find on the packaging of the product.

14.7 Cleaning the drum

Regularly examine the drum to prevent unwanted deposits.

Rust deposits in the drum may occur due to rusting foreign body in the washing or tap water containing iron

Clean the drum with special products for stainless steel.

- i** Always follow the instructions that you find on the packaging of the product.
Do not clean the drum with acidic descaling products, scouring products containing chlorine or iron or steel wool.

For a thorough clean:

1. Clean the drum with special products for stainless steel.

- i** Always follow the instructions that you find on the packaging of the product.

2. Remove all laundry from the drum.

- i** Do not use any detergent.

3. Run a cotton program with the highest temperature without detergent. If your appliance can be connected to Wi-Fi, the special program Machine Clean is also downloadable through the APP.

14.8 Cleaning the detergent dispenser

To prevent possible deposits of dried detergent, clotted fabric softener, formation of mould in the detergent dispenser, once in a while carry out the following cleaning procedure:

1. Open the detergent dispenser. Press the catch downwards as indicated in the picture and pull it out.

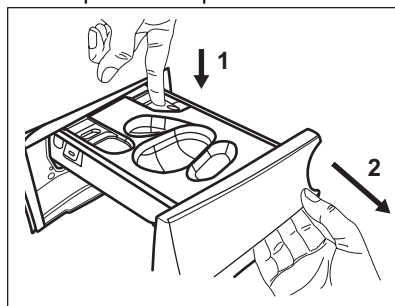

2. Remove the container for liquid detergent, if inserted.

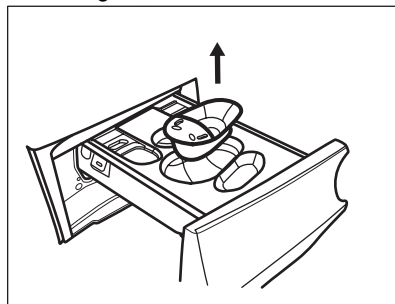

3. Lift up the top cover of the compartments to remove it.

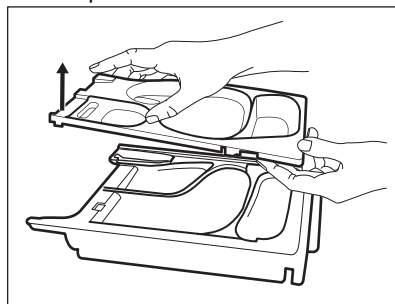

4. Wash the detergent dispenser and any insert under running water.

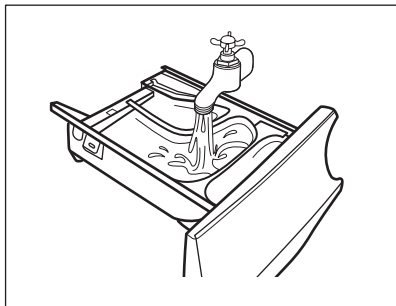

5.  **CAUTION!**
Do not use sharp or metal brushes and sponges.

Make sure that all detergent residue is removed from the upper and lower part of the recess. Use a small brush to clean the recess.

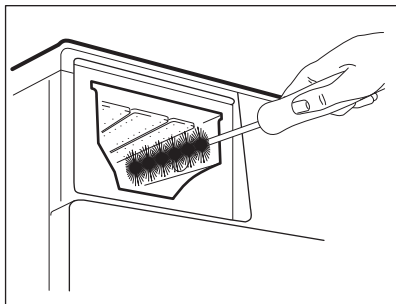

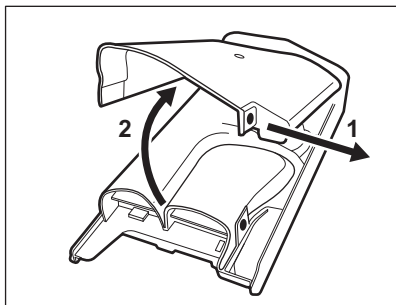

6. Turn the dispenser up side down and open the bottom cover as indicated in the picture: first pull the side tabs outwards and then remove the bottom cover.

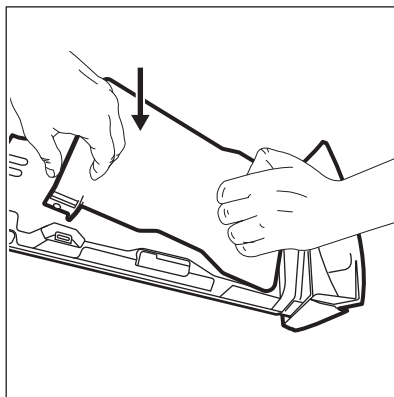

7. Make sure that all detergent residue is removed from the conveyor. Use only soft damp clothes.
8. Put bottom cover back to its position by aligning its holes on drawer hooks

as indicated in the picture. Close it till "click" sound.



-  **CAUTION!**
Press the bottom cover as indicated in the picture. Make sure that it is closed properly.

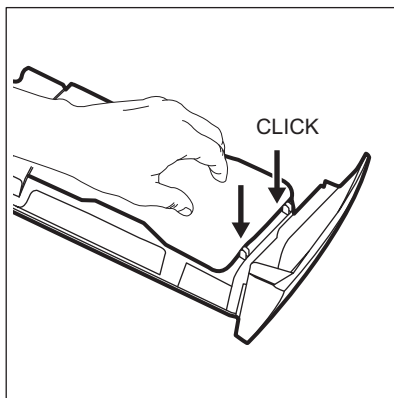

9. Reassembly the drawer as follows:
a. Place the bottom cover and press till "click" sound.
b. Place the top cover and press till "click" sound.
c. Insert the container for liquid detergent, if needed.
10. Insert the detergent dispenser into the guide rails and close it. Run the rinsing program without any clothes in the drum.

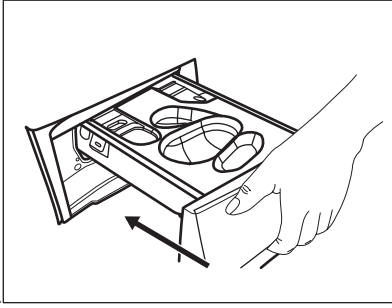

14.9 Cleaning the drain pump



WARNING!
Disconnect the mains plug from the mains socket.



Regularly check the drain pump filter and make sure that it is clean.

Clean the drain pump if:

- The appliance does not drain the water.
- The drum does not turn.
- The appliance makes an unusual noise because of the blockage of the drain pump.
- The display shows the alarm code **E20**.



- WARNING!**
- Do not remove the filter while the appliance operates.
 - Do not clean the pump if the water in the appliance is hot. Wait until the water cools down

Proceed as follows to clean the pump:

1. Open the pump cover.

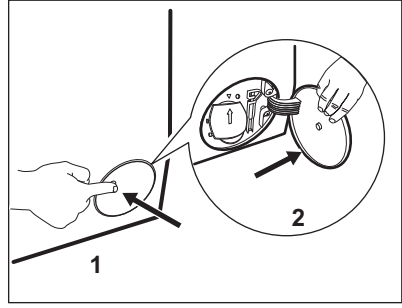

2. Place a suitable bowl below the drain pump access to collect the water that flows out.
3. Open the chute downwards. Always keep a rag nearby to dry up any water spillages when removing the filter.

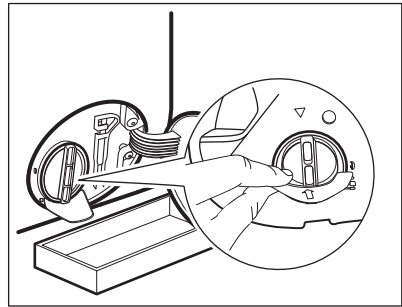

4. Turn the filter 180 degrees in anti-clockwise direction to open it, without removing. Let the water flow out.

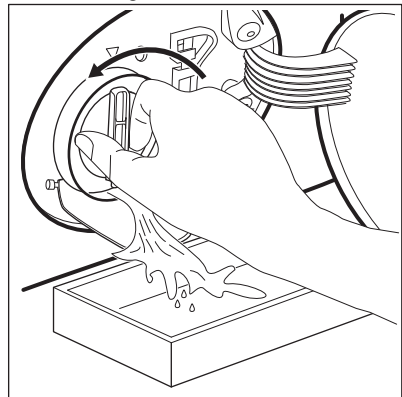

5. When the bowl is full of water, turn the filter back and empty the container.
6. Repeat the steps 4 and 5 until the water stops to flow out.

7. Turn the filter anti-clockwise to remove it.

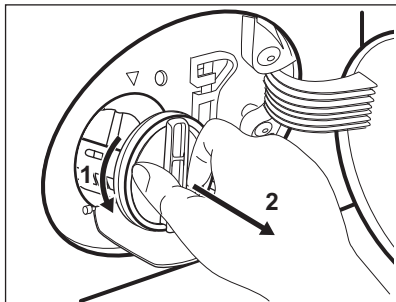

8. If it is necessary, remove fluff and objects from the filter recess.
9. Make sure that the impeller of the pump can rotate. If it does not rotate, contact the Authorised Service Centre.

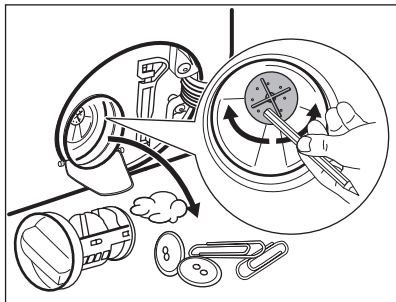

10. Clean the filter under the water tap.

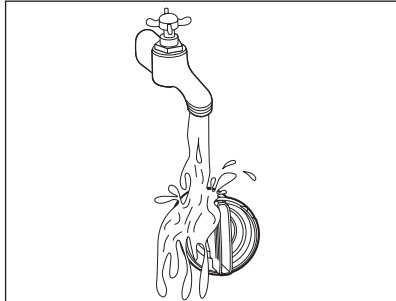

11. Put the filter back into the special guides by turning it clockwise. Make sure that you tighten the filter correctly to prevent leakages.

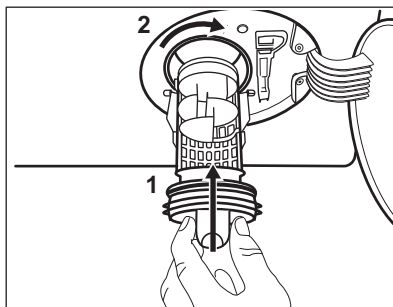

12. Close the pump cover.

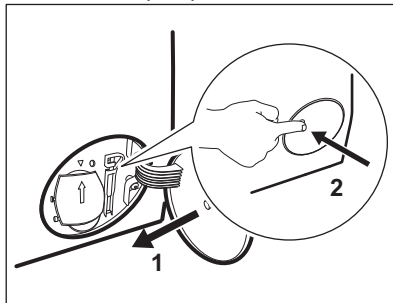

When you drain the water with the emergency drain procedure, you must activate the drain system again:

- Put 2 litres of water in the main wash compartment of the detergent dispenser.
- Start the program to drain the water.

14.10 Cleaning the inlet hose and the valve filter

It is recommended to clean both the filters of the inlet hose and valve occasionally to remove any deposit, collected over the time:

1. Remove the inlet hose from the tap and clean the filter.

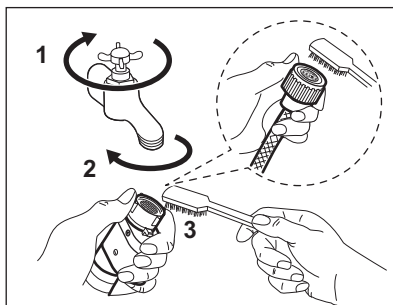

- Remove the inlet hose from the appliance by loosening the ring nut.

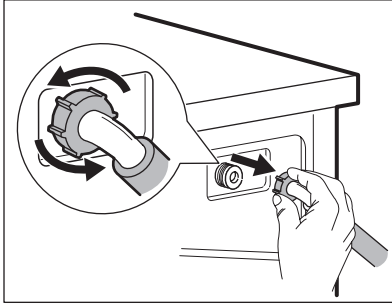

- Clean the valve filter on the back of the appliance with a toothbrush.

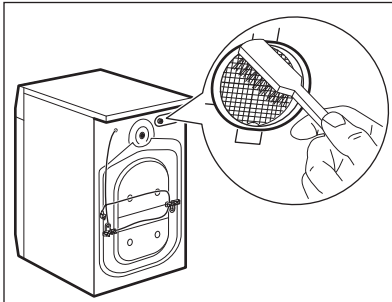

- When you reconnect the hose to the back of the appliance, turn it left or right (not in vertical position) depending on the position of your water tap.

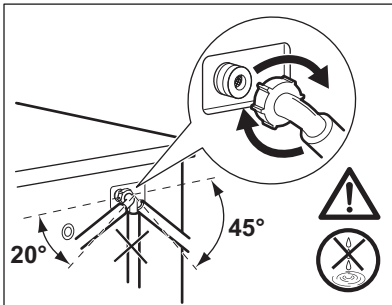

15. TROUBLESHOOTING



WARNING!
Refer to Safety chapters.

14.11 Emergency drain

If the appliance cannot drain the water, carry out the same procedure, described in 'Cleaning the drain pump' paragraph. If necessary, clean the pump.

When you drain the water with the emergency drain procedure, you must activate the drain system again:

- Put 2 litres of water in the main wash compartment of the detergent dispenser.
- Start the program to drain the water.

14.12 Frost precautions

If the appliance is installed in an area where the temperature can reach the values around 0° C or drop below, remove the remaining water from the inlet hose and the drain pump.

- Disconnect the mains plug from the mains socket.
- Close the water tap.
- Put the two ends of the inlet hose in a container and let the water flow out of the hose.
- Empty the drain pump. Refer to the emergency drain procedure.
- When the drain pump is empty, install the inlet hose again.



WARNING!

Make sure that the temperature is higher than 0 °C before you use the appliance again.

The manufacturer is not responsible for damages caused by low temperatures.



15.1 Alarm Codes and Possible failures

The appliance does not start or it stops during operation. First try to find a solution to the problem (refer to the tables).



WARNING!

Deactivate the appliance before carrying out any check.

With some problems, the display shows an alarm code and the Start/Pause  button may flash continuously:



If the appliance is overloaded, remove some items from the drum and/or keep pressed the door while touching the Start/Pause button until the indicator

 stops flashing (see the picture below).

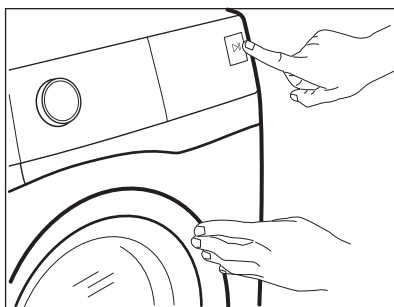



Problem	Possible solution
<p>E 10</p> <p>The appliance does not fill with water properly.</p>	<ul style="list-style-type: none"> • Make sure that the water tap is open. • Make sure that the pressure of the water supply is not too low. For this information, contact your local water authority. • Make sure that the water tap is not clogged. • Make sure that the inlet hose has no kinks, damages or bends. • Make sure that the connection of the water inlet hose is correct. • Make sure that the filter of the inlet hose and the filter of the valve are not clogged. Refer to 'Care and cleaning'.
<p>E20</p> <p>The appliance does not drain the water.</p>	<ul style="list-style-type: none"> • Make sure that the sink spigot is not clogged. • Make sure that the drain hose has no kinks or bends. • Make sure that the drain filter is not clogged. Clean the filter, if necessary. Refer to "Care and cleaning". • Make sure that the connection of the drain hose is correct. • Set the drain program if you set a program without drain phase. If the drain program is not available in the program dial, it can be set via App. • Set the drain program if you set an option which ends with water in the tub.



E40 The appliance door is open or not closed correctly.	<ul style="list-style-type: none"> • Make sure that the door is properly closed.
E91 Internal fail. No communication between electronic elements of the appliance.	<ul style="list-style-type: none"> • The program was not finished properly or the appliance stopped too early. Switch the appliance off and on again. • If the alarm code appears again, contact the Authorised Service Centre.
EFO The anti-flood device is on.	<ul style="list-style-type: none"> • Disconnect the appliance and close the water tap. Contact the Authorised Service Centre.

If the display shows other alarm codes, deactivate and activate the appliance. If the problem continues, contact the Authorised Service Centre.

In case of different problem with the washing machine check the table below for possible solutions.

Problem	Possible solution
The program does not start.	<ul style="list-style-type: none"> • Make sure that the mains plug is connected to the mains socket. • Make sure that the appliance door is closed. • Make sure that there is no damaged fuse in the fuse box. • Make sure that the Start/Pause  has been touched. • If the delay start is set, cancel the setting or wait for the end of countdown. • Deactivate the Child Lock function if it is on. • Check the position of the knob on the selected program.
The appliance fills with water and drains immediately.	<ul style="list-style-type: none"> • Make sure that the drain hose is in the correct position. The hose may be positioned too low. Refer to "Installation instruction".
The spin phase does not operate or the washing cycle lasts longer than usual.	<ul style="list-style-type: none"> • Set the spin program. If the drain program is not available in the program dial, it can be set via App'. • Make sure that the drain filter is not clogged. Clean the filter, if necessary. Refer to "Care and cleaning". • Adjust manually the items in the tub and start the spin phase again. This problem may be caused by balance problems.

Problem	Possible solution
There is water on the floor.	<ul style="list-style-type: none"> • Make sure that the couplings of the water hoses are tight and there is not water leakages. • Make sure that the water inlet hose and the drain hose have no damages. • Make sure you use the correct detergent and the correct quantity of it. • Too much detergent or unsuitable detergent creates too much foam. Reduce detergent quantity and/or use a suitable detergent.
You cannot open the appliance door.	<ul style="list-style-type: none"> • Make sure that a washing program that ends with water in tub, has not been selected. • Make sure that the washing program is finished. • Set the drain or the spin program if there is water in the drum. If the spin and drain programs are not available in the program dial, they can be set via App. • Make sure that the appliance receives electrical power. • This problem may be caused by a failure of the appliance. Contact the Authorised Service Centre. If you need to open the door, please read carefully "Emergency door opening". • Make sure that the Remote Start Mode is not activated. Deactivate it.
The display does not show the wireless indicator  .	<ul style="list-style-type: none"> • Check the wireless signal. • Make sure that the wireless connection is on. Refer to paragraph "Configuring the washing machine wireless connection" in "Wi-Fi - Connectivity setup" chapter. • Check your home network and router. • Restart the router. • Contact your wireless service provider if there are further problems with the wireless network.
The App cannot connect to the appliance.	<ul style="list-style-type: none"> • Check the wireless signal. • Check if your smart device is connected to the wireless network. • Check your home network and router. • Restart the router. • Contact your wireless service provider if there are problems with the wireless network. • The appliance, the smart device, or both, need to be configured again because a new router has been installed or the router configuration has been changed.
The App cannot frequently connect to the appliance.	<ul style="list-style-type: none"> • Make sure that the wireless signal reaches the appliance. Try to move the home router as near the appliance as possible or consider purchasing a wireless range extender. • Make sure the wireless signal is not disrupted by microwave. Turn the microwave off. Avoid using the microwave and the remote control at the same time.

Problem	Possible solution
The display shows  . All buttons are inactive, except the the On/Off  .	<ul style="list-style-type: none"> The appliance is downloading any available updates. Wait until the update process is complete. If you deactivate the appliance during update, it resumes when you activate the appliance again.
The appliance makes an unusual noise and vibrates.	<ul style="list-style-type: none"> Make sure the levelling of the appliance is correct. Refer to "Installation instruction". Make sure that the packaging and/or the transit bolts are removed. Refer to "Installation instruction". Add more laundry in the drum. The load may be too small.
The program duration increases or decreases during program execution.	<ul style="list-style-type: none"> The ProSense Technology is able to adjust the program duration according to the type and the laundry load size. Refer to "The ProSense Technology load detection" in "Daily Use" chapter.
The washing results are not satisfactory.	<ul style="list-style-type: none"> Increase the detergent quantity or use a different detergent. Use special products to remove the stubborn stains before you wash the laundry. Make sure that you set the correct temperature. Decrease the laundry load.
Too much foam in the drum during the washing cycle.	<ul style="list-style-type: none"> Reduce the quantity of detergent or the number of tablets or single-dose detergents. Too much detergent or unsuitable detergent has been used. Reduce detergent quantity and/or use a correct detergent.
After the washing cycle, there are some detergent residues in the dispenser drawer.	<ul style="list-style-type: none"> Make sure you have used the detergent dispenser according the indications given in this user manual. Make sure to use fresh tablets or single-dose detergents. Store them in their box and close it after use, according to the manufacturer's recommendations. Direct exposure to environment can modify their characteristic and their behaviour in the Pods® compartment, specially in combination with certain options (e.g. Delay Start).
The drum light does not go on.	<ul style="list-style-type: none"> Make sure that the LED lamp is not burned. To replace it, contact the Authorised Service Centre.

After the check, activate the appliance. The program continues from the point of interruption.

If the problem occurs again, contact the Authorised Service Centre. The necessary data for the service centre are on the rating plate.

15.2 Emergency door opening

In case of power failure or functioning failure the appliance door remains locked. The washing program continues when the power is restored. If the door

remains locked in case of failure, it is possible to open it using the emergency unlock function.

Before opening the door:



CAUTION!
Risk of burns! Make sure that the water temperature is not too high and the laundry is not hot. If necessary, wait until they cool down.



CAUTION!
Risk of injury! Make sure that the drum is not rotating. If necessary, wait until the drum stops rotating.



Make sure that the water level inside the drum is not too high. If necessary, proceed with an emergency drain (refer to «Emergency drain» in «Care and cleaning» chapter).

To open the door, proceed as follows:

1. Press the On/Off  button to switch the appliance off.

2. Disconnect the mains plug from the mains socket.
3. Open the filter flap.
4. Pull the emergency unlock trigger downward once. Pull it downward once again, keep it tensed and, in the meanwhile, open the appliance door.

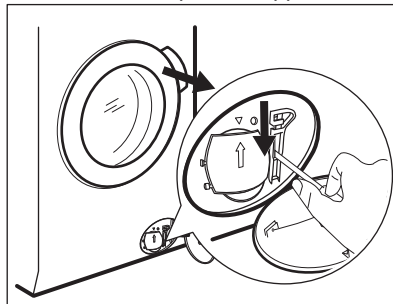



5. Take out the laundry and then close the appliance door.
6. Close the filter flap.

16. QUICK GUIDE

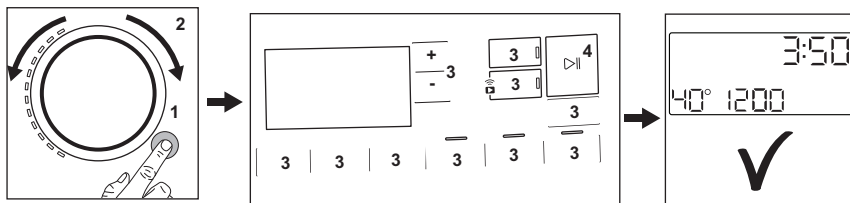
16.1 Daily use



- Connect the mains plug to the mains socket.
- Open the water tap.
- Push the **On/Off**  button to turn the appliance on (1).
- Turn the program dial to set the desired program (2).
- Set the desired options by means of the corresponding touch buttons (3).
- Put the laundry in the drum, one item a time without exceeding the maximum suggested load. Close the door and make sure that no laundry stays between the seal and the door.
- Pour the detergent and other treatments in the proper compartment of the detergent dispenser. If you use tablets, please activate the Capsules option
- To start the program, touch the **Start/Pause**  button (4).
- The appliance starts.

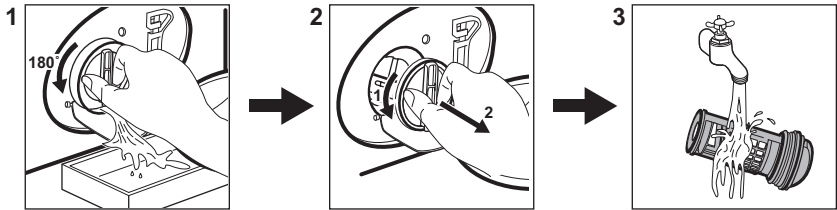

- At the end of the program, remove the laundry.
- Push the **On/Off**  button to turn the appliance off.

16.2 Cleaning the drain pump filter



Clean the filter regularly and, especially, if the alarm code **E20** appears on the display.

16.3 Programs

Programs	Load	Product description
PowerClean 59min	5.0 kg	Cotton and synthetic items. This program ensures a good washing performance in a short time.
Cottons Eco	8.0 kg	White cotton and coloured cotton. Normally, heavily and lightly soiled items. The Cottons Eco program at 40 °C is recommended for a normally soiled full load of cotton and is the water and energy rating label program in accordance with AS/NZS2040 and AS/NZS6400.
Cottons	8.0 kg	White and coloured cotton fabrics. Ideal for normal and heavy soil.
Synthetics	3.0 kg	Synthetic items or mixed fabric items.
Delicates	2.0 kg	Delicate fabrics such as acrylics, viscose, polyester items.
 Wool	2.0 kg	Machine washable wool, hand washable wool and delicates.
20min 3kg	3.0 kg	Cotton and synthetic lightly soiled items or once worn items.
 Steam	1.0 kg	Cotton and synthetic items that need to de-wrinkle.

Programs	Load	Product description
Bedlinen XL	2.0 kg ¹⁾ 1.0 kg ²⁾	Washing cycle for three bedlinen sets, one of which can be double size.
 Hygiene	8.0 kg	White cotton items. This program removes more than 99,99% of bacteria and viruses ³⁾ . It also ensure a proper reduction of allergens.
Rinse	8.0 kg	All fabrics, except woollens and very delicate fabrics. Program for rinsing and spinning.
Spin/Drain	8.0 kg	To spin the laundry and to drain the water in the drum. All fabrics, except woollens and delicate fabrics.

1) Washing program.

2) Washing program and waterproofing phase.

3) Tested for Staphylococcus aureus, Enterococcus faecium, Candida albicans, Pseudomonas aeruginosa and MS2 Bacteriophage in external test performed by Swisstest Testmaterialien AG in 2021 (Test Report No. 202120117).

17. WARRANTY - AUSTRALIA AND NEW ZEALAND

FOR SALES IN AUSTRALIA AND NEW ZEALAND

ALL AEG BRANDED APPLIANCES

This document sets out the terms and conditions of the product warranties for AEG Appliances. It is an important document. Please keep it with your proof of purchase documents in a safe place for future reference should there be a manufacturing defect in your Appliance. This warranty is in addition to other rights you may have under the Australian Consumer Law.

1. In this warranty:

- 'ACL' or 'Australian Consumer Law' means Schedule 2 to the Competition and Consumer Act 2010;
- 'Appliance' means any Electrolux product purchased by you and accompanied by this document;
- 'ASC' means Electrolux's authorised serviced centres;
- 'AEG' is the brand controlled by Electrolux Home Products Pty Ltd of 163 O'Riordan Street, Mascot NSW 2020, ABN 51 004 762 341 in respect of Appliances

purchased in Australia and Electrolux (NZ) Limited (collectively "Electrolux") of 3-5 Niall Burgess Road, Mount Wellington, in respect of Appliances purchased in New Zealand;

- 'Warranty Period' means the period specified in clause 3 of this warranty;
 - 'you' means the purchaser of the Appliance not having purchased the Appliance for re-sale, and 'your' has a corresponding meaning.
- Application:** This warranty only applies to new Appliances, purchased and used in Australia or New Zealand and is in addition to (and does not exclude, restrict, or modify in any way) other rights and remedies under a law to which the Appliances or services relate, including any non-excludable statutory guarantees in Australia and New Zealand.
 - Warranty Period:** Subject to these terms and conditions, this warranty continues for in Australia for a period of 60 months and in New Zealand for

- a period of 60 months, following the date of original purchase of the Appliance.
4. **Repair or replace warranty:** During the Warranty Period, Electrolux or its ASC will, at no extra charge if your Appliance is readily accessible for service, without special equipment and subject to these terms and conditions, repair or replace any parts which it considers to be defective. Electrolux may, in its absolute discretion, choose whether the remedy offered for a valid warranty claim is repair or replacement. Electrolux or its ASC may use refurbished parts to repair your Appliance. You agree that any replaced Appliances or parts become the property of Electrolux.
 5. **Travel and transportation costs:** Subject to clause 7, Electrolux will bear the reasonable cost of transportation, travel and delivery of the Appliance to and from Electrolux or its ASC. Travel and transportation will be arranged by Electrolux as part of any valid warranty claim.
 6. **Proof of purchase** is required before you can make a claim under this warranty.
 7. **Exclusions:** You may not make a claim under this warranty unless the defect claimed is due to faulty or defective parts or workmanship. This warranty does not cover:
 - a) light globes, batteries, filters or similar perishable parts;
 - b) parts and Appliances not supplied by Electrolux;
 - c) cosmetic damage which does not affect the operation of the Appliance;
 - d) damage to the Appliance caused by:
 - negligence or accident;
 - misuse or abuse, including failure to properly maintain or service;
 - improper, negligent or faulty servicing or repair works done by anyone other than an Electrolux authorised repairer or ASC;
 - normal wear and tear;
 - power surges, electrical storm damage or incorrect power supply;
 - incomplete or improper installation;
 - incorrect, improper or inappropriate operation;
 - insect or vermin infestation;
 - failure to comply with any additional instructions supplied with the Appliance;
- In addition, Electrolux is not liable under this warranty if:
- the Appliance has been, or Electrolux reasonably believes that the Appliance has been, used for purposes other than those for which the Appliance was intended, including where the Appliance has been used for any non-domestic purpose;
 - the Appliance is modified without authority from Electrolux in writing;
 - the Appliance's serial number or warranty seal has been removed or defaced.
8. **How to claim under this warranty:** To enquire about claiming under this warranty, please follow these steps:
 - a. carefully check the operating instructions, user manual and the terms of this warranty;
 - b. have the model and serial number of the Appliance available;
 - c. have the proof of purchase (e.g. an invoice) available;
 - d. telephone the numbers shown below.
 9. **Australia:** For Appliances and services provided by Electrolux in Australia: Electrolux goods come with guarantees that cannot be excluded under the Australian Consumer Law. You are entitled to a replacement or refund for a major failure and for compensation for any other reasonably foreseeable loss or damage. You are also entitled to have the Appliance repaired or replaced if the Appliance fails to be of acceptable quality and the failure does not amount to a major failure. 'Acceptable quality' and 'major

failure' have the same meaning as referred to in the ACL.

10. **New Zealand:** For Appliances and services provided by Electrolux in New Zealand, the Appliances come with a guarantee by Electrolux pursuant to the provisions of the Consumer Guarantees Act, the Sale of Goods Act and the Fair Trading Act. Where the Appliance was purchased in New Zealand for

commercial purposes the Consumer Guarantee Act does not apply.

11. **Confidentiality:** You accept that if you make a warranty claim, Electrolux and its agents including ASC may exchange information in relation to you to enable Electrolux to meet its obligations under this warranty.

Important Notice

Before calling for service, please ensure that the steps listed in clause 8 above have been followed.

SERVICE AUSTRALIA aeg.com/au

FOR SERVICE

or to find the address of your nearest authorised service centre in Australia

PLEASE CALL 1300 363 664

OR EMAIL

customercare@aegaustralia.com.au

For the cost of a local call (Australia only)

FOR SPARE PARTS

or to find the address of your nearest spare parts centre in Australia

PLEASE CALL 13 13 50

OR EMAIL

customercare@aegaustralia.com.au

For the cost of a local call (Australia only)

SERVICE NEW ZEALAND aegnewzealand.co.nz

FOR SERVICE

or to find the address of your nearest authorised service centre in New Zealand

PLEASE CALL 0800 234 234

OR EMAIL

customercare@electrolux.co.nz

(New Zealand only)

FOR SPARE PARTS

or to find the address of your nearest spare parts centre in New Zealand

PLEASE CALL 0800 10 66 20

OR EMAIL

customercare@electrolux.co.nz

(New Zealand only)

AEG_Warr_May_17

18. ENVIRONMENTAL CONCERNS

Recycle materials with the symbol . Put the packaging in relevant containers to recycle it. Help protect the environment and human health by recycling waste of electrical and electronic appliances. Do not dispose of

appliances marked with the symbol  with the household waste. Return the product to your local recycling facility or contact your municipal office.



The software in this product contains components that are based on free and open source software. AEG gratefully acknowledges the contributions of the open software and robotics communities to the development project.

To access the source code of these free and open source software components whose license conditions require publishing, and to see their full copyright information and applicable license terms, please visit: <http://aeg.opensourcerepository.com> (folder NIUS)