

SFP9302TX

90CM CLASSIC PYROLYTIC OVEN

MADE IN ITALY

 Since 1948



THERMOSEAL

The seal of Smeg's quality, technical excellence and taste: succulent roasts, crisp pastry and impressive baking is achieved in Smeg's unique, perfectly controlled cooking environment. ThermoSeal maintains the perfect atmospheric balance in the cavity for optimum cooking conditions.

PYROLYTIC CLEANING

Smeg's pyrolytic cycle locks the door and heats the oven to around 500°C. This process carbonises any food residue or burnt-on grease to a small amount of ash, which can be simply wiped away with a damp cloth.



EVER CLEAN ENAMEL

The superior quality of Smeg's signature Ever Clean enamel, which is highly durable and easy to clean, is the result of over 70 years of enameling expertise; ensuring long-life performance of every Smeg oven.

COOL DOOR TECHNOLOGY

Smeg's Cool Door system is a combination of technologies which is driven by a 22 blade tangential fan and includes a heat exchange baffle system. It draws cool air up through the panes of heat-reflective glass in the door, making it safe to the touch even when the oven is at pyrolytic temperatures of around 500°C.



TEN TRADITIONAL COOKING FUNCTIONS:



OTHER FUNCTIONS:

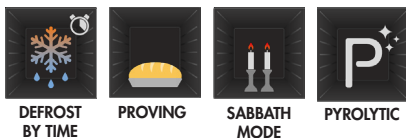

SFP9302TX

90CM CLASSIC PYROLYTIC OVEN

MADE IN ITALY
Since 1948

OVEN FEATURES

EAN	8017709325466
Dimensions	896mmW x 593mmH x 573mmD
Finish	Stainless steel Eclipse high visibility black glass
Cooking functions	10
Other functions	4
Display	EvoScreen
Capacity	126L
Shelf positions	5
Thermostat	30° C - 280° C
Fans	3
Smart cooking	No
Cooking with probe	No
DeltaT cooking	No
SameTime	No
Multi-step cooking	No
Rapid pre-heat	Yes
Instant GO	Yes
Installation	Built-in
Cleaning	Pyrolytic
Lighting	2 x 40W Halogen
Safety	Thermal protection system, control lock
Timer	Delay start and automatic end cooking 1 x Minute minder
Door	Soft close
Power	220-240V, 50/60Hz 4000W 18A Connection
Warranty	Two years parts and labour

OVEN FUNCTIONS

TEN TRADITIONAL COOKING FUNCTIONS:



OTHER FUNCTIONS:

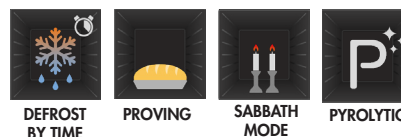

INCLUDED ACCESSORIES

- 2 x Chrome shelves
- 1 x Chrome grill insert
- 1 x 20mm enamelled baking tray
- 1 x 40mm enamelled baking tray
- 1 x GTP Partial telescopic guides

OPTIONAL ACCESSORIES

- GTP - Partial telescopic guides
- GTT - Full telescopic guides
- PPR9 - Pizza stone

SFP9302TX
90CM CLASSIC PYROLYTIC OVEN

MADE IN ITALY
Since 1948

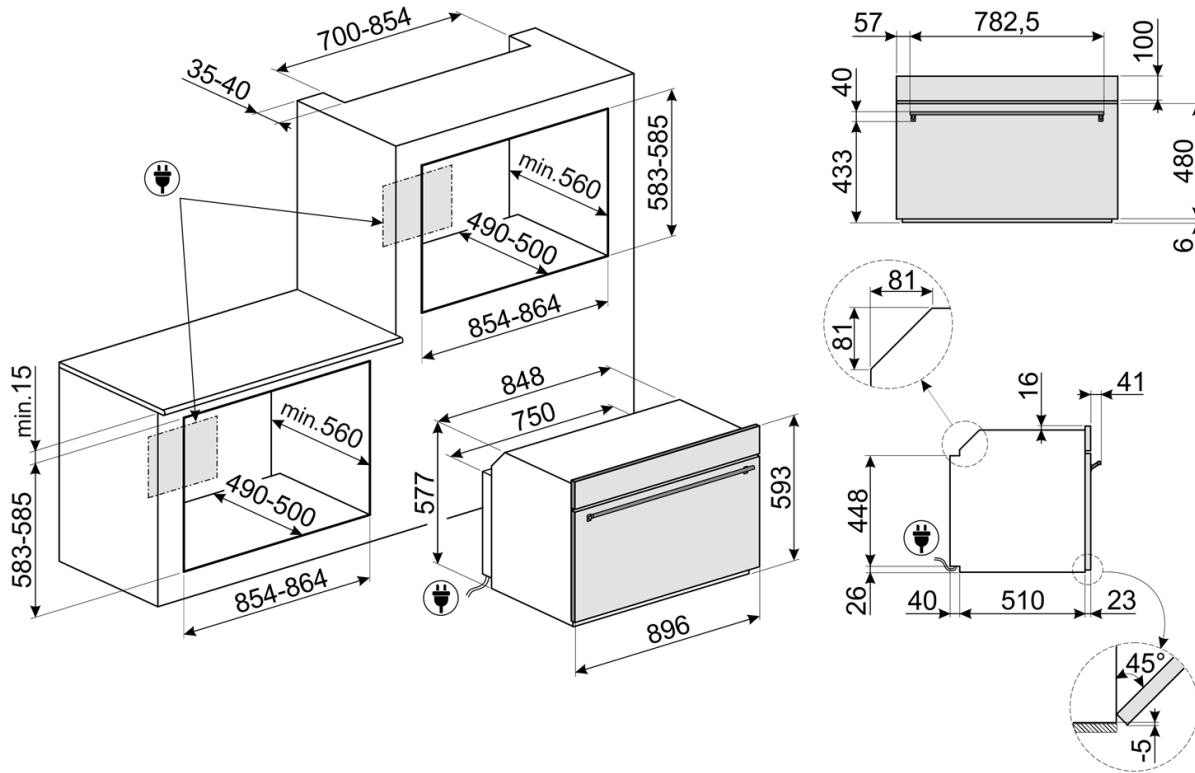

Dimensions	896mmW x 593mmH x 573mmD
Power	220-240V, 50/60Hz
	4000W
	18A Connection

PLEASE NOTE: drawings are not to scale. They are to assist only.
WARNING: technical specifications and product sizes can be varied by the manufacturer without notice.
Cutouts for appliances should only be by physical product measurements. The above information is indicative only.