

We advise you to read this manual carefully, which contains all the instructions for maintaining the appliance's aesthetic and functional qualities. For further information on the product: www.smeg.com

Apple, App Store and iOS are trademarks of Apple Inc.

Google Play Store and Android are trademarks of Google Inc.

Wi-Fi is a trademark of Wi-Fi Alliance.

PRECAUTIONS

General safety instructions

Risk of personal injury

- Keep children under the age of 8 at a safe distance unless they are constantly supervised.
- This appliance may be used by children aged at least 8 and by people of reduced physical, sensory or mental capacity, or lacking in experience in the use of electrical appliances, provided that they are supervised or instructed by adults who are responsible for their safety.
- This appliance is not suitable for use by persons (including children) with reduced physical, sensory or mental capacity, or by those without experience or knowledge, unless they are supervised or instructed on the use of the appliance by a person responsible for their safety.
- Children must be supervised to ensure that they do not play with the appliance.
- According to current regulations, children between 3 and 8 years of age can take or load food from the appliance, but it is highly discouraged to allow children under 8 years of age to perform these operations and in general to use the appliance.
- Children must never play with the appliance.
- Never try to put out a fire or flames with water: turn off the appliance and smother the flames with a fire blanket or other appropriate cover.
- Cleaning and maintenance must not be carried out by unsupervised children.
- Installation and servicing should be carried out by qualified personnel in accordance with current standards.
- Do not modify this appliance.
- Do not insert pointed metal objects (cutlery or utensils) into the slots in the appliance.

- Do not try to repair the appliance yourself or without the assistance of a qualified technician.
- Do not pull the cable to unplug the appliance.
- If the power supply cable is damaged, contact technical support immediately and they will replace it.
- If it is necessary to replace the power cable, this must be performed by an authorised technician from Technical Support Service.
- DO NOT USE OR STORE FLAMMABLE MATERIALS NEAR THE APPLIANCE.
- DO NOT USE AEROSOLS IN THE VICINITY OF THIS APPLIANCE WHILST IT IS IN USE.
- DO NOT MODIFY THIS APPLIANCE.
- Installation and servicing should be carried out by qualified personnel in accordance with current standards.

Risk of damaging the appliance

- Never rest sharp metal objects such as knives, forks, spoons and lids on the appliance during use.
- Do not use cleaning products containing chlorine, ammonia or bleach on parts made of steel or that have metallic surface finishes (e.g. anodizing, nickel- or chromium-plating).
- Do not use abrasive or corrosive detergents (e.g. scouring powders, stain removers and metallic sponges) on glass parts.
- Do not use rough or abrasive materials or sharp metal scrapers.
- Do not sit on the appliance.
- Do not rest any weight or sit on the open door of the appliance.
- Take care that no objects are stuck in the doors.
- Do not store inflammable, explosive or volatile substances (e.g. spray bottles with flammable propellants).
- Organic compounds, acids and essential oils can corrode the seals and plastic surfaces if left in contact with them for extended periods.
- Bottles with a high alcohol content must be tightly closed.
- Do not place bottles sideways on the base of the wine cellar. They could fall when the door is opened.
- Do not use steam jets to clean the appliance.
- Do not spray any spray product near the appliance.
- Do not obstruct ventilation openings and heat dispersal slots.
- Do not obstruct the openings of the ventilation

grille in any way.

- Do not use electrical appliances inside food storage compartments unless these are of the type recommended by the manufacturer.
- **DO NOT USE THE APPLIANCE TO COOL ROOMS FOR ANY REASON.**
- Never use mechanical devices or any other means not recommended by the manufacturer to accelerate the defrosting process.
- Always unplug the appliance in the event of a fault or when performing cleaning or maintenance.
- Avoid exerting too much pressure on the door when open.
- Do not use the handle to lift or move this appliance.
- **CAUTION:** while positioning the appliance, make sure that the power supply cable is not caught or damaged.
- **CAUTION:** do not place portable multiple sockets or portable power supply units at the back of the appliance.

For this appliance

- The appliance may only be used by children aged 8 years and over, and by people of reduced physical, sensory or mental capacity, or lacking in experience and

knowledge in the use of the appliance, provided that they instructed on safe use of the appliance and the risks connected to it by adults who are responsible for their safety.

- Do not rest any weight or sit on the open door of the appliance.
- The appliance contains a small quantity of isobutane (R600a), make sure not to damage the cooling circuit during transport, installation and cleaning.
- Keep the ventilation openings surrounding the appliance or in the nearby area free from any obstructions.
- Do not damage the cooling circuit (if it can be accessed).
- In the event of damage to the cooling circuit, avoid the use of naked flames and ventilate the area properly.
- Do not use the appliance or parts of it in ways other than those specified in this manual.
- **Caution:** risk of fire, flammable materials.



- Opening the door for long periods can cause the temperature in the

appliance compartments to rise considerably.

- Clean surfaces that may come into contact with accessible drainage systems regularly.
- If the appliance is left empty for long periods of time, switch it off, clean it, dry it and leave the door open to prevent the development of mould inside.

Installation and maintenance

- THIS APPLIANCE MUST NOT BE INSTALLED IN A BOAT OR CARAVAN.
- The appliance must not be installed on a base.
- Position the appliance into the cabinet cut-out with the help of a second person.
- To prevent any possible overheating, the appliance should not be installed behind a decoration door or a panel.
- Do not install/use the appliance outdoors.
- The appliance must not be exposed to direct sunlight.
- The appliance must not be installed near heat sources. If this is not possible, suitable insulation must be used.
- Attention: keep the ventilation openings in the appliance housing or in the built-in structure free from any obstructions.
- Do not use the appliance outdoors.
- Never use the oven door to lever the appliance into place when fitting.
- Installation and servicing should be carried out by qualified personnel in accordance with current standards.
- Have the electrical connection performed by authorised technical personnel.
- The appliance must be connected to earth in compliance with electrical system safety standards.
- The plug must always be accessible when the appliance is installed or a switch must be incorporated in the fixed system in compliance with installation regulations.
- CAUTION: while positioning the appliance, make sure that the power supply cable is not caught or damaged.
- CAUTION: do not place portable multiple sockets or portable power supply units at the back of the appliance.
- CAUTION: to avoid dangers due to the instability of the appliance, it must be fixed according to the instructions.
- Use cables withstanding a temperature of at least 90°C.
- The tightening torque of the

screws of the terminal supply wires must be 1.5 - 2 Nm.

- Always use any necessary/required personal protective equipment (PPE) before performing any work on the appliance (installation, maintenance, positioning or movement).
- Before performing any work on the appliance, switch off the main power supply.
- Opening the door for long periods can cause the temperature in the appliance compartments to rise considerably.
- If the appliance is left empty for long periods of time, switch it off, clean it, dry it and leave the door open to prevent the development of mould inside.
- This appliance can be used up to a maximum altitude of 2,000 metres above sea level.

Appliance purpose

- This appliance has been designed exclusively for storing wine in a domestic setting. Every other use is considered improper.
- The appliance is not designed to operate with external timers or with remote-control systems.

The appliance is designed for use in a domestic or similar environment, for instance:

- staff kitchen areas in shops,

offices and other working environments;

- farm houses and by guests in hotels, motels and other residential type environments;
- bed and breakfast establishments;
- catering and similar non-retail applications.



This appliance may only be installed and used indoors.

This user manual

- This user manual is an integral part of the appliance and must therefore be kept in its entirety and within the user's reach for the whole working life of the appliance.
- Read this user manual carefully before using the appliance.
- The explanations in this manual include images, which describe all that regularly appears on the display. However, it should be kept in mind that the appliance may be equipped with an updated version of the system, and as such, all that appears on the display may differ from those in the manual.

Manufacturer's liability

The manufacturer declines all liability for damage to persons or property caused by:

- use of the appliance other than that specified;
- failure to comply with the instructions in the user manual;
- tampering with any part of the appliance;
- use of non-original spare parts.

Technical Support.

- In the event of failure of the appliance, contact the technical support and have the repair carried out by qualified personnel only.
- make sure you have the model and serial number available on the identification plate.
- Use original spare parts only.
- Do not try to repair the appliance yourself or without the assistance of a

qualified technician: this affects safety and may void the warranty.

- Original spare parts for some specific components remain available for a minimum of 7 or 10 years, depending on the type of component, from the date the model is put on the market.
- For the duration or further details on the warranty, please refer to the relevant warranty booklet.
- For troubleshooting, assistance, and repair information, please refer to the contacts for your country specified in the warranty booklet or visit the website:

www.smeg.com/services/customer-service

Identification plate

The identification plate bears the technical data, serial number and brand name of the appliance. Do not remove the identification plate for any reason.

Energy label

To be informed about the performance of your device via the EU EPREL database visit the following web address and enter the model name (available on the identification plate):

<https://eprel.ec.europa.eu>

On the energy label there is a QR code for a quick access to the web address. Use a device equipped with an appropriate reading program.

The energy label must be kept together with all documents supplied with the appliance.

Disposal



This appliance conforms to the WEEE European directive (2012/19/EU) and must be disposed of separately from other waste at the end of its service life.

The appliance does not contain substances in quantities sufficient to be considered hazardous to health and the environment, in accordance with current European directives.



Power voltage
Danger of electrocution

- Disconnect the mains power supply.
- Unplug the appliance.

To dispose of the appliance:

- Cut the power cable and remove it.
- Deliver the appliance to the appropriate recycling centre for electrical and electronic equipment waste, or return it to the retailer when purchasing an

equivalent product, on a one for one basis.

Our appliances are packaged in non-polluting and recyclable materials.

- Deliver the packing materials to the appropriate recycling centre.



Plastic packaging
Danger of suffocation

- Do not leave the packaging or any part of it unattended.
- Do not let children play with the plastic bags.

Information for control bodies

- For EcoDesign checks, the installation and preparation of the appliance must comply with EN 62552 standard.
- Ventilation requirements, dimensions and minimum space from the rear wall are indicated in the "Installation" chapter of this manual.
- Contact the manufacturer for more information.

To save energy

- Reduce any opening of the door to a minimum to avoid temperature dispersal.
- Whenever the appliance is to remain unused for long periods, it should be switched off.

Light sources

- This appliance contains light sources which cannot be replaced by the user and must only be replaced by the technical assistance service.

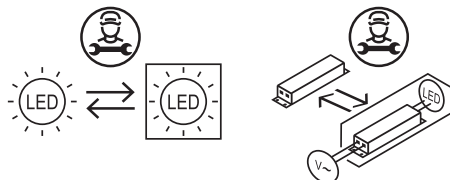

- This appliance contains light sources of efficiency class "A".

How to read the user manual

This user manual uses the following reading conventions:



Warning/Caution



DESCRIPTION

General description

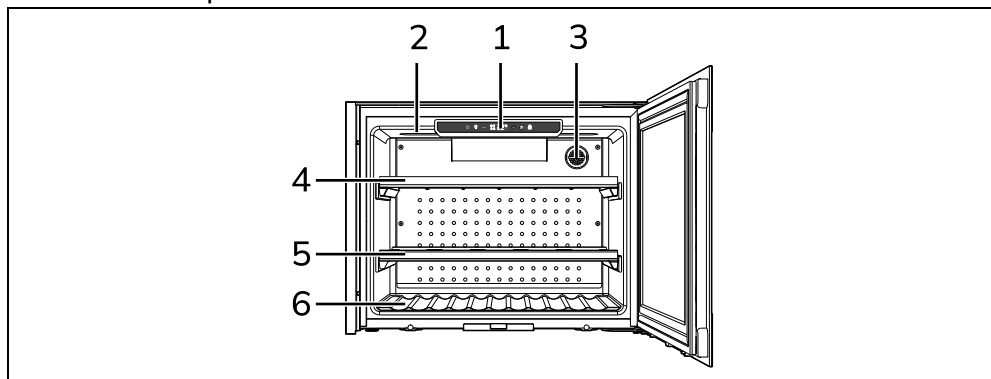

- 1 Control panel
- 2 Interior lighting
- 3 Activated charcoal filter

- 4 Upper removable shelf
- 5 Central removable shelf
- 6 Lower shelf

Control panel



ON/OFF key

It switches on and off the appliance and (on some models only) activates the control panel.

Forced light key

It turns the lighting inside the wine cellar on and off.

 The forced light turns off automatically after a maximum period of 15 minutes.

Decrease key

It decreases the temperature inside the wine cellar.

Increase key

It increases the temperature inside the wine cellar.

Controls lock key

It disables the key of the control panel.

Manual ventilation key

It activates or deactivates the manual ventilation mode to increase humidity inside the wine cellar.



If manual ventilation is deactivated, the fan will automatically activate according to the software settings.

Bell key

 (on some models only)

It deactivates the audible warning when an alarm is triggered.

Description of parts

Activated charcoal filters

Ensure optimum air quality for wine storage.

Fans (not visible)

Distribute the temperature and reduce condensation on the shelves and other surfaces.

Interior lighting

The appliance's interior lighting comes on:

- with light pressure in the upper area of the door.
- when the door is opened.
- when the forced lighting button on the control panel is pressed. 

Removable shelves

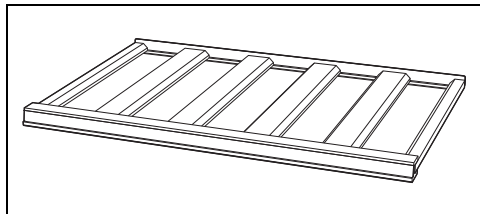

The removable shelves allow easy removal of the bottles of wine.

Smeg Connect (on some models only)

The appliance is equipped with the Smeg

Connect technology so that the user can control its operation through an App on his smartphone or PC tablet.

For further information, refer to the supplied brochure and/or visit the site

www.smeg.com

Removable trims (only on some models)

The appliance is fitted with removable trims. The appliance trims can be replaced by selecting from the available colours; for this purpose, follow the instructions provided in the kit, available separately.



Optional accessories can be requested from Authorised Assistance Centres. Use only original accessories supplied by the manufacturer.

USE

Preliminary operations





See General safety instructions.



1. Remove any protective film from the outside or inside of the appliance, including accessories.
2. Remove any labels (apart from the technical data plate) from the accessories and shelves.
3. Remove and wash all the appliance accessories (see chapter "CLEANING AND MAINTENANCE").

First use

To turn on the appliance:

1. Press the ON/OFF  key on the control panel;
2. select the required temperature for the interior of the wine cellar by pressing the Increase  or Decrease  keys (from 5°C to 20°C).





Each press of the Increase  or Decrease  key changes the temperature by 1°C.

To turn off the appliance:

3. Press and hold the ON/OFF  key on the control panel for a few seconds.

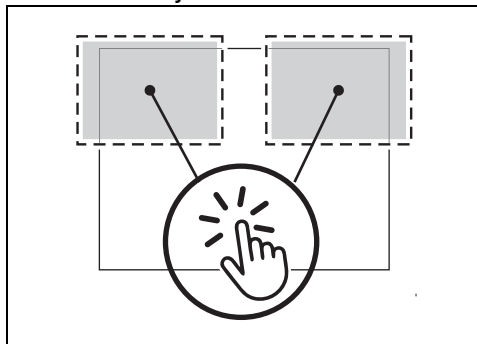
E MOTION System



through the system  MOTION.

Device door opening



Improper use
Risk of malfunction

- Do not place magnetic objects near the appliance.
- Do not block the door while it is opening.
- Do not hold the door opening device.

The appliance is equipped with a semi-

automatic door opening system.

To activate the device, press at the top of the door against the opening direction.

The door will open a few centimetres and from there you can grasp it to open it completely.

Using the control panel

Interior lighting



The interior lighting is provided by an LED light bar installed at the top of the wine cellar.

The lighting comes on via:

- system **MOTION** (simple touch).
- the door opening.
- the forced lighting button on the control panel being pressed .



- The forced interior lighting will stay on for a maximum of 15 minutes.
- Interior lighting activated by opening the door or by the system **MOTION** is brighter than activation via the forced lighting button .

Manual ventilation



The fans switch on and off automatically to guarantee a constant temperature and provide suitable climate control for conservation of the wine.

If increasing the level of humidity inside the wine cellar is necessary, it is possible to activate the manual ventilation mode. The manual ventilation mode forces the continuous operation of the fan.



If the manual ventilation mode is deactivated, the fan goes back to the standard automatic operation.

Select this option occasionally in order to prevent corks from drying out when bottles are stored for long periods.

To activate manual ventilation:

1. if necessary (on some models only) activate the control panel using the ON/OFF key .

2. press the fan  key.



If manual ventilation is activated, the energy consumption will be higher.

To deactivate manual ventilation:



press the fan  key again.

Control lock



This function prevents the appliance functions from being accidentally switched on/off.

To activate the control lock:

1. if necessary (on some models only), press the ON/OFF  key to activate the control panel.
2. Press and hold the control lock  key for a few seconds.

To deactivate the control lock:







3. Press and hold the control lock  key for a few seconds.

Demo mode (for showrooms only)







Turns off the appliance's fans and compressor while keeping the control panel active.

To activate demo mode:

1. press the ON/OFF  key to activate the control panel.
2. press and hold the fan  and control lock  keys simultaneously for a few seconds. The text  will appear on the display;
3. press the fan  key. The text  will appear on the display.
4. after a few seconds, without any key being pressed, the selection is stored.

To deactivate demo mode:

5. press and hold the fan  and control lock  keys simultaneously for a few seconds. The text  will appear on the display;
6. press the fan  key. The text  will appear on the display.



When demo mode is active, the display will show the message  for 2 seconds every 2 minutes.









In demo mode, forced lighting will have no time limit for switching off.

Temperature format (on some models only)







Allows you to set the temperature scale to degrees Celsius (°C) or degrees Fahrenheit (°F).

To change the temperature display format:

1. if necessary (on some models only), press the ON/OFF  key to activate the control panel.
2. press and hold the fan  and temperature increase  keys simultaneously for a few seconds. The text  will appear on the display.
3. press the fan  key. The text  will appear on the display.
4. after a few seconds, without any key being pressed, the selection is stored.

To return to the previous format:

5. press and hold the fan  and control lock  keys simultaneously for a few seconds. The text  will appear on the display;
6. press the fan  key. The text  will appear on the display.

Using the wine cellar compartments

Bottle arrangement

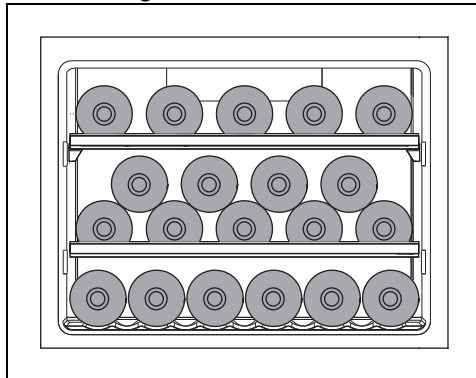

- A maximum of 20 Bordeaux-type 0.75 litre bottles can be stored.
- Each pull-out shelf can support a maximum load of 10 kg.

The upper shelf can hold up to 5 Bordeaux-type 0.75 litre wine bottles or 5 champagne-type bottles.

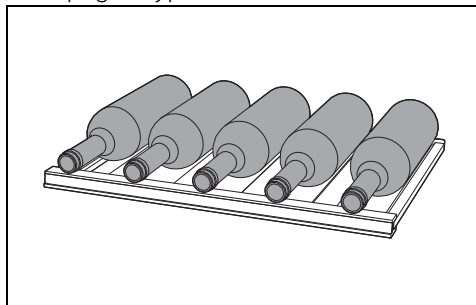

The central shelf can hold up to 9 Bordeaux-type 0.75 litre wine bottles or 5 champagne-type bottles.

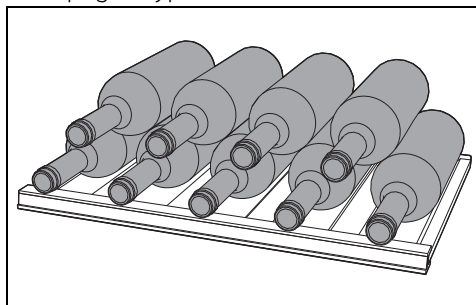

Up to 6 x 0.75 litre bottles can be placed on the base of the wine cellar or 5 champagne-

type bottles.

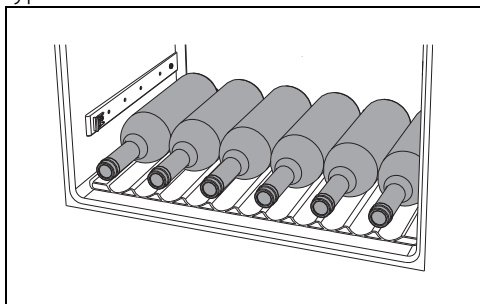



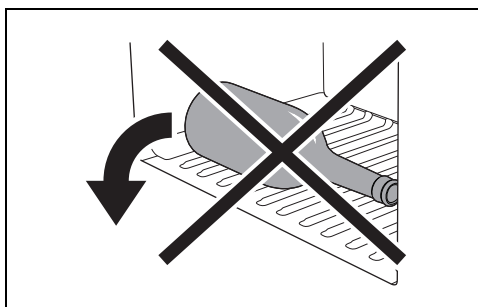



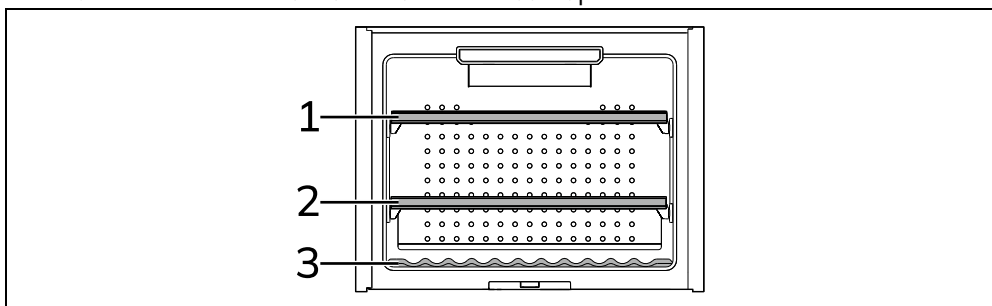



Do not place bottles horizontally on the base of the wine cellar. They could fall out when the door is opened.



The number of bottles that can be accommodated per shelf



Shelf	 Bordeaux-type		 Alsace-type		 champagne-type	
	number of bottles	mode	number of bottles	mode	number of bottles	mode
1	5		-	-	5	
2	5 + 4*		-	-	5	
3	6		6		5	

 all facing in the same direction with the cork toward the door.

4* The bottles should be placed in the second row.

Activated charcoal filter



To maintain optimum air quality inside the wine cellar, the activated charcoal filter must be replaced at least once a year.

To replace the activated charcoal filter:

1. turn the filter cap 90° to the left or right.

2. Extract the cap from its seat.

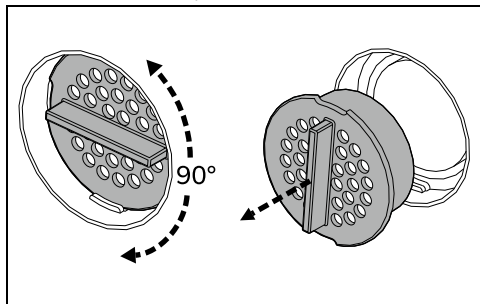

3. Replace the activated charcoal filter with a new one.
4. Replace the filter cap following the indications in points 1 and 2.



Replacement filters can be ordered from Authorised Service Centres.

Noises during operation

The wine cellar is cooled by means of a compression system. In order to maintain the preset temperature inside the wine cellar, the compressor comes into operation in response to the level of cooling required, and may operate continuously if necessary. When the compressor starts up a humming sound will be heard, tending to drop in volume after a few minutes.

Another normal wine cellar operating noise is a gurgling due to the refrigerant flowing through the pipes in the circuit. This noise is normal and does not indicate an appliance malfunction.

Turning the appliance off

Whenever the appliance is to remain unused for long periods, it should be switched off.

1. Press and hold the ON/OFF  key on the control panel for a few seconds until the appliance turns off.
2. Unplug the appliance from the wall socket.
3. Empty the wine cellar.
4. Dry any residual moisture which has accumulated with a soft cloth.

Leave the door ajar to prevent the humidity and trapped air from creating unpleasant smells.

Connectivity alarms (on some models only)

Alarms



The alarms help protect the wine from temperatures which could compromise its quality.

Each alarm consists of a message flashing on the display, and an audible warning. The display continues to flash until the alarm condition finishes.

- To deactivate the alarm press any key or the key  (if available).

Temperature alarm

The temperature on the display may start to flash. This means that the temperature inside the wine cellar compartment is too high or too low in relation to that set.

This may occur:

- when the appliance is first turned on;
- if a temperature much higher or much lower than the previous one is set;
- if the wine cellar is loaded with many bottles at ambient temperature;
- in the event of an extended interruption in mains voltage.

These conditions may occur during normal operations of the appliance and are not caused by problems/faults.

In this case, deactivate the alarm through any key on the control panel (or, on some models only, through the key ) and wait for the temperature to return within the normal storage values. It may be necessary to repeat this operation 1–2 times.



If the alarm continues to occur, call Technical Support.

Alarm for door open

The display shows **ES**; the door has been left open for more than 60 seconds.

- Close the door.



The alarm will reactivate in the same way 60 seconds after it is shut off if the door is still open.

Fault alarms

The display shows from **E1** to **E9** (**ES** excluded) or **EA** or **EL** or **EE** or **EF**: appliance fault.

- Switch off the appliance and call Technical Support.

The display shows **EE**: appliance fault.

The App shows : appliance fault.

- Contact technical support.

For further information, please read the Connectivity Manual.



In case of alarm  the appliance continues cooling wines.

Storage advice

White wines

White wines are generally more acidic than reds and contain less tannin. To be enjoyed at its best, an acidic drink should usually be stored at a slightly lower temperature than other types, and so these wines should be stored at a temperature between 10°C and 14°C.

Young, fresh, aromatic white wines can be served at a temperature as low as 10°C, while for less aromatic wines 12°C is recommended. For full, mature white wines which have aged in the bottle for a few years, higher temperatures are acceptable and they can be served at between 12°C and 14°C.

Serving a white wine at a higher temperature means emphasising its “sweet” properties, while the acidity and sharpness considered pleasant and desirable in wines of this kind will be less noticeable.

Rosé wines

Generally, the rules for serving rosé wines are the same as for whites. However, it is important to consider these wines' tannin content and serve them at a higher temperature if necessary so that their flavour is not too sharp. Tannin content permitting, young, fresh rosé wines are served between 10°C and 12°C, while more robust, full-bodied types, including more mature wines, can be served between 12°C and 14°C.

Red wines

The serving temperature for red wines depends on a great deal of factors, but in view of their higher tannin and lower acidity than whites, they are usually served at higher temperatures. Young red wines with low tannin are usually served between 14° and 16°C, while for more full-bodied types 16°C or in exceptional cases even 18°C may be recommended.

Young red wines high in tannins and with a fairly uncomplicated structure can be served at between 12°C and 14°C without

tasting too sharp, and will still be very pleasant. This rule applies to “nouveau” wines, made by a special method which reduces their tannin content; they can be appreciated to the full at cooler temperatures than other red wines.

Sparkling wines

In view of the large number of types of sparkling wines on the market, there would be little sense in laying down one rule to fit them all. Sweet, aromatic white sparkling wines can be served at a temperature as low as 8°C. Their aromatic nature means they are excellent at low temperatures.

Sweet red sparkling wines such as Brachetto may be served at temperatures between 10°C and 12°C. Here again, the more aromatic sparkling wines are suitable for lower temperatures, even down to 8°C, while those with a slightly higher tannin content require temperatures as high as 14°C.

Dry sparkling wines made by the “Charmat method” or “Martinotti method”, such as some Prosecco wines, can be served at temperatures between 8°C and 10°C.

Sparkling wines made by the “traditional method” and the “méthode Champenoise”, such as Champagne, require special consideration: in general these sparkling wines are served at temperatures between 8°C and 10°C. However, for prestige wines marked with the vintage, or sparkling wines that have been aged for a long time, even 12°C may be advisable to allow the development of the complex bouquet that has been slowly and painstakingly built up over the years.

Dessert wines and fortified wines

These two types of wine generally both contain a high alcohol percentage and they are both often also sweet. However, there are dry dessert wines, such as Marsala, with a sugar content so low as to be almost imperceptible on the palate. For these wines, the serving temperature depends on which features you wish to emphasise. If you prefer to accentuate the wine's sweetness, the complexity of its bouquet and its austerity, it should be served at a high temperature, between 14°C and 18°C. Remember that in this case its alcohol content will also be more in evidence.

If you require a fresher sensation, or to reduce the sweetness of over-sweet wines, serve at a lower temperature, between 10°C and 14°C.

Young, fresh, dry dessert wines can be

served at colder temperatures, below 10°C. This makes the alcohol content considerably less noticeable. However, remember that as the temperature is reduced the bouquet also becomes less evident. One of these wines' key characteristics is the charm and complexity of their bouquet; serving them too cold also means sacrificing this important feature.

Storage temperatures

To enjoy the flavour and bouquet of each wine at its best, it should be stored and drunk at a specific temperature. The recommended temperatures for different kinds of wines are given below.

Type of wine	Temp. (°C)
Young whites	10 - 12
Mature whites	12 - 14
Young, light rosés	10 - 12
Mature, full-bodied rosés	12 - 14
Nouveau reds	10 - 14

Type of wine	Temp. (°C)
Young, light reds with low tannin	14 - 16
Mature, full-bodied reds with high tannin	16 - 18
Very mature and cask-aged reds	16 - 18
Sweet and aromatic sparkling wines	8
Sweet and aromatic red sparkling wines	10 - 12
"Charmat method" sparkling wines	8 - 10
"Long Charmat method" sparkling wines	10 - 12
"Traditional method" sparkling wines without year	8 - 10
"Traditional method" sparkling wines with year	10 - 12
Dessert wines	10 - 18
Fortified or liqueur wines	10 - 18

CLEANING AND MAINTENANCE

Cleaning the appliance



See General safety instructions.

They must be cleaned regularly in order to keep them in good condition.

Cleaning the outside of the appliance

- The appliance may be cleaned with water or alcohol-based liquid detergents (e.g. window cleaning products).
- Avoid aggressive detergents and rough sponges in order not to damage the surfaces.

Cleaning the inside of the appliance

- Clean the inside of the appliance with diluted liquid detergent and warm water, adding a little bit of vinegar.

Cleaning the removable shelves

- Use a soft, damp cloth to clean the removable shelves. Avoid the use of soaps and detergents and/or sponges which could damage both the wooden and steel surfaces.

Extracting the removable shelves

The removable shelves can be extracted from the interior of the wine cellar to facilitate cleaning.

Removing the pull-out shelves

1. Open the door.
2. Pull the shelf out.

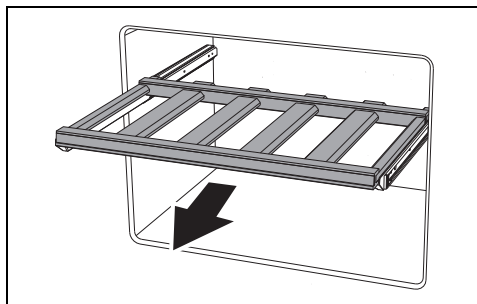

3. Remove any bottles present.
4. Lift the removed shelf upwards.

5. Position the shelf correctly again on the guides.

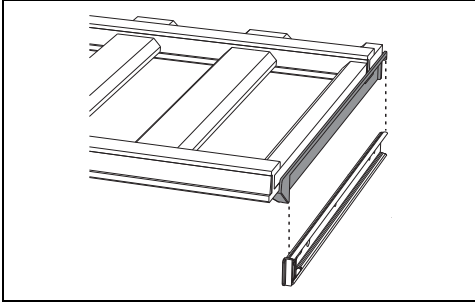

What to do if...

The appliance does not work:

- Make sure that the appliance is plugged in and that the main switch is turned on.

The compressor starts to function too often or functions continuously:

- The room temperature is too high.
- The door is being opened too often or for

too long.

- The door is not closing/sealing properly.
- There is an excessive quantity of non-cooled bottles.

There is excessive condensate build-up inside the wine cellar:

- The door is being opened too often or for too long.
- Warm bottles have been placed inside the wine cellar.
- The door seal is damaged or dirty. Clean or replace it.

Water builds up inside the wine cellar:

- The drainage channel or opening is blocked.

The wine cellar cooling is insufficient:

- The temperature set on the display is too high.
- The door is being opened too often or for too long.
- The door is not closing/sealing properly.
- The room temperature is too high.

INSTALLATION

Electrical connection



See General safety instructions.

General information

- Check the mains characteristics against the data indicated on the plate. The identification plate bearing the technical data, serial number and brand name is visibly positioned inside the appliance. Do not remove this plate for any reason.
- Make sure that the plug and socket are of the same type.
- Avoid using adapters, gang sockets or shunts as these could cause overheating and a risk of burns.
- Leave the appliance standing for at least two hours before turning it on for the first time.
- If it is necessary to replace the power cable, this must be performed by an authorised technician from Technical Support Service.

Positioning

Choice of location



Refrigerator designed for use at an ambient temperature of between 10°C and 38°C.

Always install the appliance in a dry place with satisfactory ventilation. Depending on its climate class (stated on the nameplate inside), the wine cellar can be used in different temperature conditions.

- Position the appliance at least 3 cm away from electrical or gas cookers and at least 30 cm away from combustion heaters or radiators.
- The appliance must not be installed near heat sources. If this is not possible, suitable insulation must be used.
- Ensure that the appliance is located with sufficient space for the door to open and for the internal drawers and shelves to be removed, if necessary.
- To ensure correct cooling of the condenser, follow the clearance requirements when mounting.

Levelling

To level the appliance correctly, there are

two feet on the lower front.

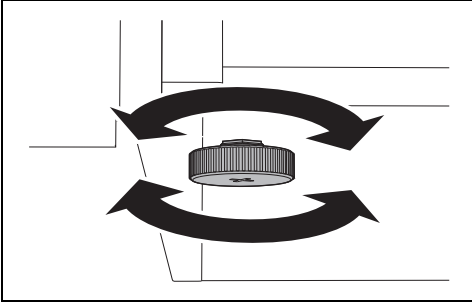

Fixing to the furniture

To fix the appliance to the furniture:

1. open the door;
2. tighten the 4 screws provided.



Strong tightening
Risk of damage to the appliance

- Take care not to exert too much force when tightening the screws, the side parts may deform.

3. cover the screws with the supplied bushings.

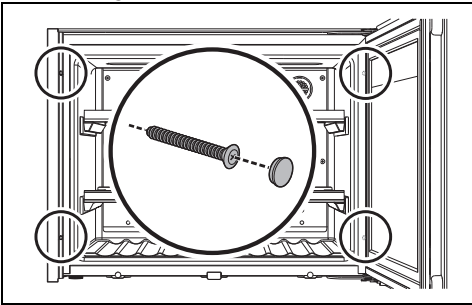

Reverse the door opening direction (on some models only)

Should it be necessary to reverse the direction of the door opening from right to left:

1. remove the two screws of the lower hinge.

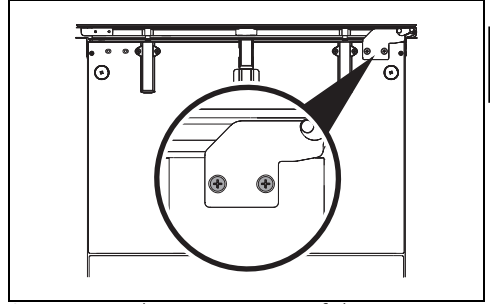

2. remove the two screws of the upper hinge.

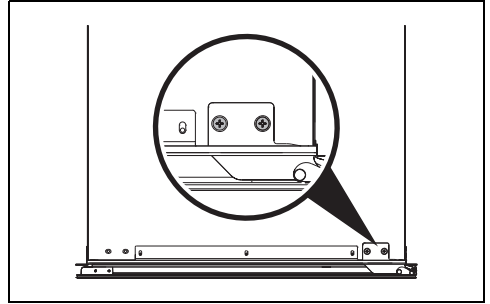

3. remove the door from the appliance and place it on a cloth.
4. remove the hinge block fixing screws from the door.

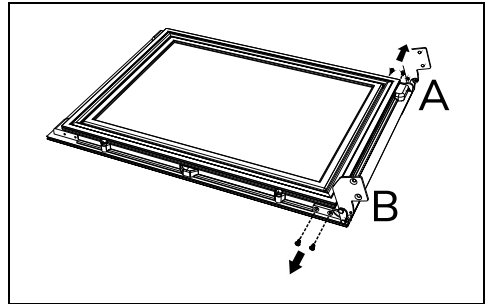

5. reposition the hinges on the other side by reversing their direction. The upper right hinge (A) will become the lower left hinge. The lower right hinge (B) will become the upper left hinge.

6. Fasten the hinges with the previously removed screws.

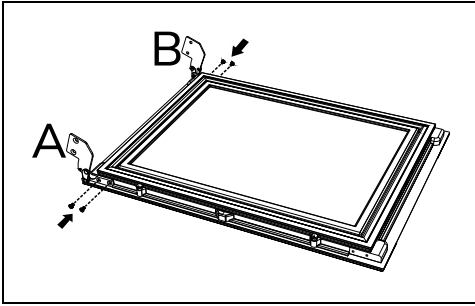

Appliance overall dimensions (mm)

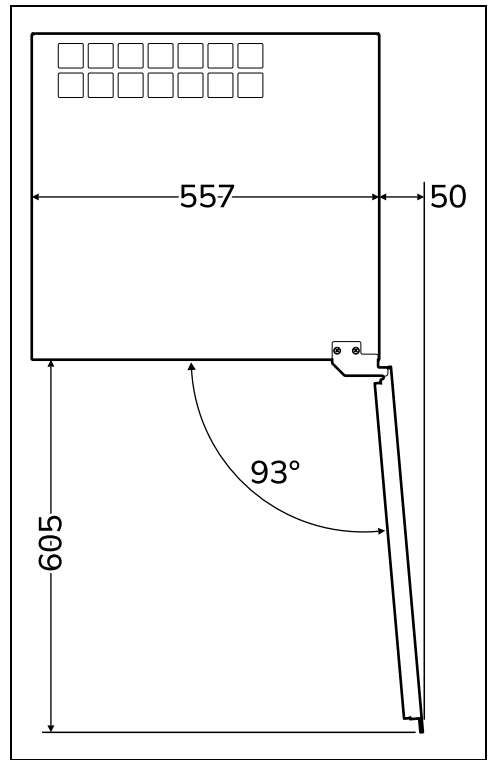
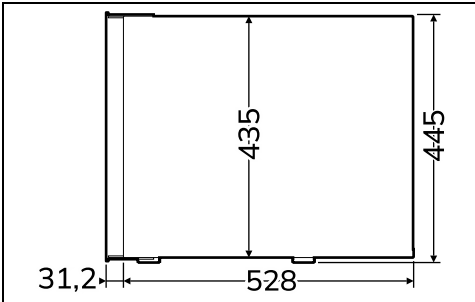
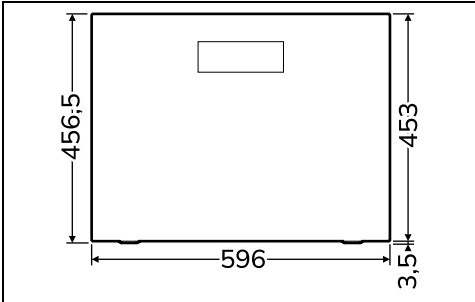

Mounting (mm)



Do not cover the ventilation holes.

