

60cm fully integrated dishwasher with connectivity. Comes with 7 wash programs, featuring SprayZone, MaxiFlex cutlery drawer, ComfortRails and ProClean™ satellite spray arm to deliver a perfect wash result, regardless of your load.

RRP AUS \$2,199.00



Product Details

FEATURES

Wifi Connectivity
Dishwashing on your terms with The AEG App.

MaxiFlex
Accommodate different kitchen tools with MaxiFlex.

SprayZone
SprayZone uses high pressure water for excellent results.

GlassCare
GlassCare protects and gently cleans glassware.

ExtraPower
ExtraPower use a boost to remove stubborn dirt.

ExtraHygiene
ExtraHygiene for hygienic dish cleaning.

EcoProgram
EcoProgram reduces energy and water consumption.

AutoSense
AutoSense optimises the wash cycle for any load.

BENEFITS

SMART REMOTE DISHWASHING

Experience customised dishwashing by connecting your appliances to The AEG App. Get guidance of which program to run based on load, time and soil level. Control off-peak hours to run the dishwasher to save energy cost. The app summarises and provides ECO reports. The app sends reminders and guides on how to maintain the dishwasher and the Machine Care program.

DARE TO USE EVERY KITCHEN TOOL

The MaxiFlex drawer is designed to fit cutlery and utensils of different shapes and sizes. Its increased depth offers greater capacity in each load. Whether large or awkwardly-shaped, the customisable dividers and deep drawer mean everything can be loaded with ease.

ULTIMATE TOUGH CLEANING

Get exceptional results with SprayZone function that activates a dedicated area specially designed for dishes with tough stains and food residue. The intensive cleaning treatment with high water pressure in the dedicated area ensures removal of even the most stubborn stains and residues without pre-rinsing or soaking.

GENTLE CARE FOR YOUR GLASSWARE

The unique SoftGrip feature ensures that the stem and foot of every glass are held gently but firmly in exactly the right position throughout the duration of the program. Protected from vibration. Removing the risk of breakages. And with SoftSpikes you no longer need to spend time handwashing delicate glasses. The soft material gently holds glasses securely in place and protects them from cracks and breakage.

IMPROVE WASHING RESULTS

ExtraPower function improves the washing results of the selected program. The extra boost in wash temperature and duration rids stubborn stains from your kitchenware with immaculate results.

HYGIENIC CARE FOR YOUR DISHES

The ExtraHygiene function gives you maximum cleaning performance with hygienic care. With the ExtraHygiene function, the final rinse phase heats up to 69°C and keeps the temperature high for minimum 10 minutes to sanitize your dishes.

HIGH PERFORMANCE. LOW ENERGY

By selecting the EcoProgram you can rest assured that your dishes will be cleaned using the lowest possible amount of energy and water for the load, without compromising on wash performance.

OPTIMISE TIME, ENERGY AND WATER

AutoSense detects the soil level and load size and adjusts settings accordingly to deliver an optimised wash program for the load. This delivers incredible cleaning performance.

Specifications

PRODUCT PROFILE

Domestic warranty details (yrs)	5
Type of Dishwashers	fully integrated
Place settings	15
Drying system	AirDry
Number of spray arms	3
Top shower	Yes

DIMENSIONS

Total height (mm)	818
-------------------	-----

SPECIFICATION

Water Efficiency Star Rating	5
WELS Registration Number	D02851
Water consumption (litres)	12.2
Energy Efficiency Star Rating	4
Energy consumption cold water (kWhr/yr)	246
Noise level dBA	44
Water supply	cold or hot (maximum 60°C)
Basket colour	grey
Service cord length	1600
Inverter system	Yes

BUILT-IN DIMENSIONS

Door panel minimum weight (kg)	1.5
--------------------------------	-----

DIMENSIONS

Total width (mm)	596
Total depth (mm)	550

BUILT-IN DIMENSIONS

Door panel maximum weight (kg)	10
Door panel minimum height (mm)	670
Door panel maximum height (mm)	825
Plinth height minimum (mm)	0
Plinth height maximum (mm)	220

WASH PROGRAMS

Number of Programs	7
Programs	Quick 30 min,Regular 90 min,AUTO Sense,Machine Care,Light 60 min,Heavy 160 min,ECO 180 min
Wash option	Delay start (1-24 hours),GlassCare,ExtraPower,SprayZone
Range of temperatures	4

CONTROL PANEL

Control panel type	LCD display
Top mounted control panel	Yes
Control panel finish	black
Display indicators	delay start,rinse aid,service code,TimeBeam on Floor,program selected,GlassCare,ExtraPower,ExtraSilent,My Time

FEATURES

Other Features	interior light,Auto Off,MaxiFlex drawer with ComfortRails,TimeBeam on Floor indicator,AEGConnected
Water safety system	aqua control
Dispenser	detergent,rinse aid

UPPER BASKET

Upper basket features	soft spikes for tall glass,SoftGrip,Foldable glass rack,ComfortRail,easy lift adjustable upper basket
Foldable cup shelves	4
Foldable Racks	2

HOSES

Inlet hose length	1800
Drain hose length	1800
extension hose	spare part

EXTERIOR

Door finish	your cabinetry
Side colour	grey
Plinth colour (kickboard)	no plinth supplied
Removable worktop	No

LOWER BASKET

Lower Basket Features	SprayZone
Foldable Racks	4
Foldable cup shelves	0

SHIPPING

Shipping Volume (m3)	0.376
Shipping Weight (Kg)	40.1
Pack Dimensions Height (mm)	870
Pack Dimension Width (mm)	635

SHIPPING

Pack Dimension Depth (mm)	680
------------------------------	-----

STUFFING QUANTITIES

40ft HC	150
---------	-----

Dimensions

Model:
FBF7533SBA

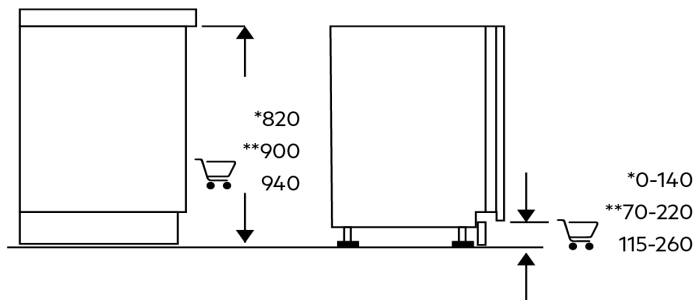
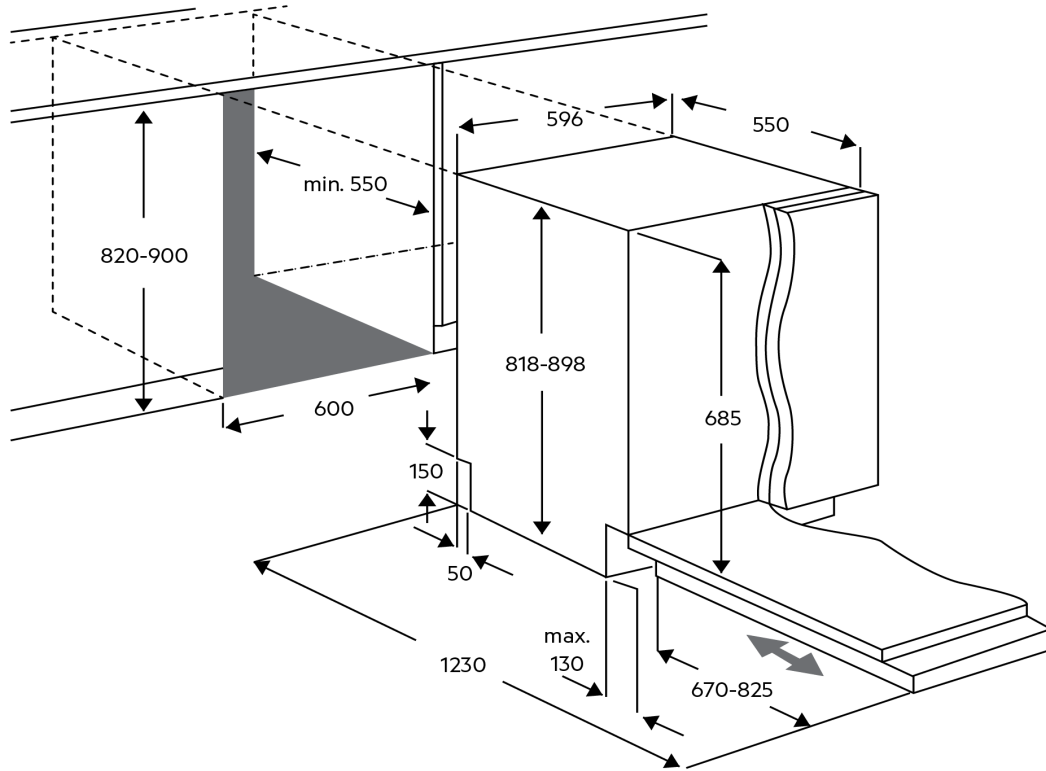

© 2023 Electrolux S.E.A PTE. LTD. AEG_IM_Diag_FBF7533SBA_Nov23

Terms and Conditions

IMPORTANT

This is a guide of product dimensions only. For complete installation instructions, refer to the manual provided with product.

PRODUCT INFORMATION

The descriptors and illustrations in this publication apply to the specific products and models described as at the date of issue. Under our policy of continuous product development, product specifications may change without notice. Prospective purchasers should therefore check with their retailer to ensure this publication correctly describes the products that are being offered for sale. All information supplied is to be used for general reference purposes only and is on the understanding that Electrolux Home Products Pty Ltd (Australia) and Electrolux (NZ) Ltd (New Zealand) will not be liable for any loss, liability or damage of whatever kind arising as a result of reliance on such information. Colours of products illustrated are as close as printing limitations allow. Electrolux will at all times comply with its obligations pursuant to law including Trade Practices (Australian Consumer Law) Act and Regulations.

WARRANTY

Electrolux Home Products warrants that for domestic applications the AEG appliances featured are free from defects in materials and workmanship for 5 years (3 months warranty for commercial applications). All warranties are subject to the conditions set out in the warranty card accompanying the product when purchased.

ELECTROLUX HOME PRODUCTS AUSTRALIA

telephone: 1300 363 664

fax: 1800 350 067

email: customercare@aegaustralia.com.au

web: www.aeg.com/au

ELECTROLUX HOME PRODUCTS NEW ZEALAND

telephone: 0800 10 66 10

fax: 09 573 2221

email: customercare@electrolux.co.nz

web: www.aeg.com/au