

80cm 4 zone induction cooktop with integrated rangehood, bridging zones, touch slide control and Hob2Hood.

RRP AUS \$5,999.00

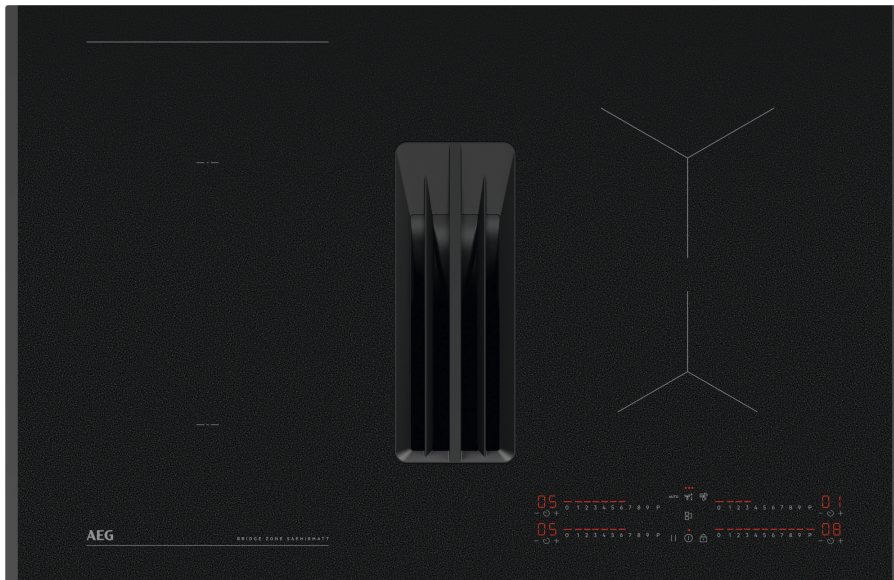

Product Details

FEATURES

Bridge with eXtractor Hob
 Bridge with eXtractor Hob enhances kitchen design freedom and links zones for cooking flexibility.

SaphirMatt AntiScratch Surface
 The matt black ceramic cooking surface, scratch resistant and easy to clean keeping the hob looking new for longer.

Reusable carbon filters
 Maintain carbon filters with ease to ensure optimal extraction for fresher, cleaner kitchen air.

Individual zone controls
 Individual Zone Controls with separate timers and independent functions including PowerBoost and ActiveTouch.

Automatic Extractor Control
 Automatic Extractor Control adjusts as you cook

Timer
 The integrated timer helps you to plan your cooking when multi-tasking in the kitchen.

Pause Function
 The pause function sets zones to the lowest setting to keep dishes warm and prevent overcooking.

Child lock

BENEFITS

MORE ROOM TO COOK

Experience kitchen planning freedom and flexibility with the Bridge with eXtractor Hob. This induction hob has a built-in extractor and Bridge function allowing you to combine two cooking zones into one large zone for greater versatility. Effortlessly accommodate large pots and long pans to master recipes that require specialist cookware, such as fish kettles and plancha grill plates.

SUPERIOR SCRATCH PROTECTION

The SaphirMatt AntiScratch surface provides superior protection against scratching compared to our standard ceramic hob surfaces*. The elegant black matt finish is resistant to fingerprints and stains making it easy to clean - keeping your hob looking new for longer. *Based on external tests, compared to our standard hob surface without special treatment or coating.

CARBON FILTERS FOR FRESHER AIR

Carbon filters effectively absorb odours to create a cleaner cooking environment. Reusable, low-maintenance carbon filters are simple to remove and can be easily washed by hand or in the dishwasher. Clean regularly to ensure optimal extraction performance for fresh kitchen air, constantly.

UNLIMITED COOKING OPTIONS

Individual Zone Controls allow you to create completely self-contained cooking areas. Each zone has separate timers and independent functions, including PowerBoost, ActiveTouch and child lock for customised control to finesse your cooking experience.

HANDS-FREE AUTO EXTRACTION

Automatic Extractor Control keeps your hands free to focus on what's important your cooking. The hob will automatically switch on and regulate the extractor according to your cooking activities, keeping your kitchen fresh while you concentrate on creating a delicious meal.

ITS ALL ABOUT TIMING

The integrated timer helps you to plan your cooking when multi-tasking in the kitchen. Program the desired duration and your appliance will automatically notify you when its time to check on your dishes.

WHY NOT HIT PAUSE

The pause function is useful if your cooking is interrupted. At the touch of a button all cooking zones will be reduced to the lowest heat setting to ensure dishes stay warm, but dont overcook.

CHILD PROOF

Activate the child lock function to prevent accidental operation of the hob when it's not in use.

Specifications

PRODUCT PROFILE

Domestic warranty details (yrs)	5
Cooktop type	induction
Materials/Colour	matte black
Trim finish	bevelled sides only

DIMENSIONS

Total product height (mm)	229
Total product width (mm)	800
Total product depth (mm)	510
Cut out width (mm)	750
Cut out depth (mm)	490
Cut out height (mm)	225

CONTROLS

Controls of Cooktops	Touch and Slide controls
Position of controls	front
Functions of Cooktops	automatic switch off,Hob2Hood,timer,pause,Bridging,PowerBoost,Child-lock
Indicators/display	residual heat warning lamps,3 level residual heat indicator
Features of Cooktop	minute minder,function lock,sound off,Hob2Hood Connectivity,Bridge zone

ELEMENTS/BURNERS

LEFT FRONT ZONE

Left front zone	Bridge
Left front Watts	2300
Left front boost watts	3200
Left front diameter mm	210

CONTROLS

Timer of Cooktop countdown

LEFT REAR ZONE

Left rear zone Bridge

Left rear watts 2300

Left rear diameter mm 210

RIGHT FRONT ZONE

Right front zone induction

Right front Watts 1400

Right front diameter mm 145

RIGHT REAR ZONE

Right rear zone induction

Right rear watts 1800

Right rear diameter mm 180

ELECTRICAL SPECIFICATIONS

Connected load KW 7.35

Type of connection hardwired

SHIPPING

Shipping Volume (m3) 0.167

Shipping Weight (Kg) 20.28

Pack Dimensions Height
(mm) 330

OTHER FEATURES

Integrated extractor Yes

Hob2Hood Yes

Timer Yes

Filter type grease filter

SHIPPING

Pack Dimension Width (mm)	875
---------------------------	-----

Pack Dimension Depth (mm)	580
---------------------------	-----

OTHER FEATURES

Filter indicator	Yes
------------------	-----

Motor type	brushless
------------	-----------

Recirculation max (m3/h)	650
--------------------------	-----

Recirc sound power dB(A)	71
--------------------------	----

Dimensions

AEG

DIMENSION AND INSTALLATION GUIDE

6000 SERIES
NCH84B03FZ
 80CM BUILT-IN INDUCTION HOB

Dimensions	Width (mm)	Height (mm)	Depth (mm)
Cut-out (mm)	750-780	225	490
Product (mm)	800	229	510

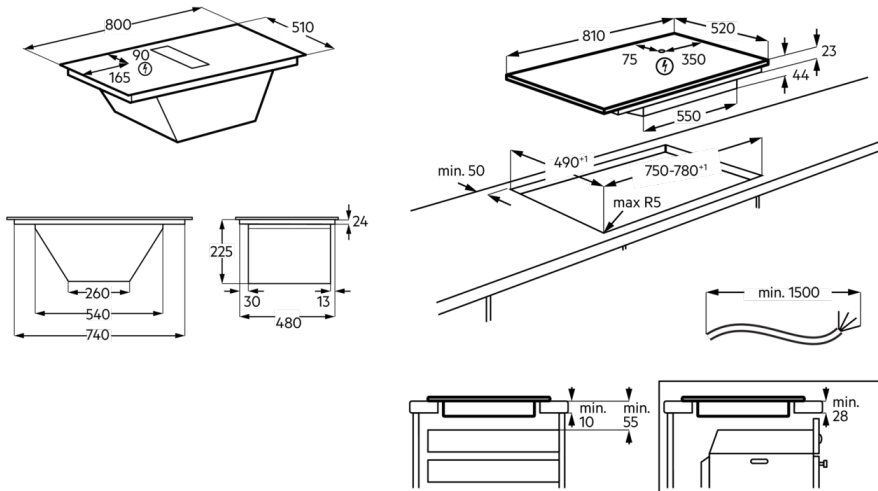

IMPORTANT

These dimensions are a guide only. All measurements are in millimetres (mm).
 For complete installation instructions, refer to the manual provided with product.

© 2024 Electrolux S.E.A PTE. LTD. AEG_DIM_NCH84B03FZ_Oct24

Terms and Conditions

IMPORTANT

This is a guide of product dimensions only. For complete installation instructions, refer to the manual provided with product.

PRODUCT INFORMATION

The descriptors and illustrations in this publication apply to the specific products and models described as at the date of issue. Under our policy of continuous product development, product specifications may change without notice. Prospective purchasers should therefore check with their retailer to ensure this publication correctly describes the products that are being offered for sale. All information supplied is to be used for general reference purposes only and is on the understanding that Electrolux Home Products Pty Ltd (Australia) and Electrolux (NZ) Ltd (New Zealand) will not be liable for any loss, liability or damage of whatever kind arising as a result of reliance on such information. Colours of products illustrated are as close as printing limitations allow. Electrolux will at all times comply with its obligations pursuant to law including Trade Practices (Australian Consumer Law) Act and Regulations.

WARRANTY

Electrolux Home Products warrants that for domestic applications the AEG appliances featured are free from defects in materials and workmanship for 5 years (3 months warranty for commercial applications). All warranties are subject to the conditions set out in the warranty card accompanying the product when purchased.

ELECTROLUX HOME PRODUCTS AUSTRALIA

telephone: 1300 363 664

fax: 1800 350 067

email: customercare@aegaustralia.com.au

web: www.aeg.com/au

ELECTROLUX HOME PRODUCTS NEW ZEALAND

telephone: 0800 10 66 10

fax: 09 573 2221

email: customercare@electrolux.co.nz

web: www.aeg.com/au