

**Serie | 8, downdraft hood, 80 cm,
clear glass
DDW88MM66**



Optional accessories

DSZ1WW1B6 , DSZ1WW1I6 Clean Air Plus recirculation kit, DSZ1WW1J1 , DSZ1WW1M1 Installation kit remote motor, DSZ8WW1Y2 Mounting kit for seamless installation, HEZ9VDSB1 , HEZ9VDSB2 , HEZ9VDSI0 , HEZ9VDSI1 , HEZ9VDSM1 , HEZ9VDSM2 , HEZ9VDSS1

GlassDraft module: perfect extraction directly behind the cooktop, regardless of pot height and pot position.

- **Decorative LED-illumination of retractable glass panel:** the perfect additional, atmospheric lighting in your kitchen.
- **PerfectAir sensor:** automatic control of settings for maximal extractor performance with minimal noise.
- **Guided Air:** perfect extraction performance regardless of pot height and pot position.
- **Cook2Hood control:** convenient control of Glass Draft Module functions via the cooktop.
- **Brushless EcoSilence Drive motor:** durable, quite and efficient.

Technical Data

Approval certificates :	CE, VDE
Length electrical supply cord (cm) :	130
Required niche size for installation (HxWxD) :	703mm x 781.0mm x 123mm
Net weight (kg) :	39.746
Type of control :	Electronic
Number of speed settings :	3-stage + 2 intensive
Maximum output air extraction (m ³ /h) :	501
Boost position output recirculating (m ³ /h) :	525
Maximum output recirculating air (m ³ /h) :	416
Boost position air extraction (m ³ /h) :	775
Noise level (dB) :	62
Diameter of air outlet (mm) :	150
Grease filter material :	Washable stainless steel
Odour filter :	No
Operating Mode :	Convertible
Delay Shut off modes :	10
Optional accessories :	DSZ1WW1B6, DSZ1WW1I6, DSZ1WW1J1, DSZ1WW1M1, DSZ8WW1Y2, HEZ9VDSB1, HEZ9VDSB2, HEZ9VDSI0, HEZ9VDSI1, HEZ9VDSS1, HEZ9VDSI1, HEZ9VDSM1, HEZ9VDSM2
Grease filter type :	Kassette
Connection Rating (W) :	300
Current (A) :	10
Voltage (V) :	220-240
Frequency (Hz) :	50; 60
Plug type :	Gardy plug w/ earthing
Installation typology :	Built-in
Material body :	Glass
Approval certificates :	CE, VDE
Plug type :	Gardy plug w/ earthing
Dimensions of the product, with chimney (if exists) (in) :	/ x x
Dimensions of the packed product (in) :	24.01 x 44.88 x 34.25
Net weight (lbs) :	88.000
Gross weight (lbs) :	103.000
Motor location :	Integrated motor in hood body
No-return airflow flap :	No
Length electrical supply cord (cm) :	130
Dimensions of the product, with chimney (if exists) (mm) :	x 816.0 x 140.0
Dimensions of the packed product (HxWxD) (mm) :	610 x 1140 x 870
Net weight (kg) :	39.746
Gross weight (kg) :	46.7



4 242005 223657

Serie | 8, downdraft hood, 80 cm, clear glass DDW88MM66

GlassDraft module: perfect extraction directly behind the cooktop, regardless of pot height and pot position.

Variant

- 80 cm wide
- For installation in a kitchen cabinet
- Perfect for installation in an island or Semi-island kitchen solution
- Ducted and recirculated-air operation
- For recirculated extraction Clean Air Plus recirculation kit (accessory) needed

Design

- The clear glass panel provides a glass edge lighting and is extendable via lift motor
- The appliance comes in an extraordinary glass design equipped with red edge lighting. Simply choose your favorite color via Homeconnect.

Comfort

- Electronic metal soft-touch controls with LED indicators
- The user interface to the left provides extended functions
- The standard functions are located on the right-hand user interface
- TouchControl for power and light
- 3 power levels + 2 intensive levels
- Intensive operation automatic revert - 6min
- Automatic run on for Automatic run on - 10 min
- Air Quality sensor
- Cooktop-based hood control (with matching cooktop)
- fully automatic rangehood

Cleaning

- Activate Guided Air to guarantee nearly perfect extraction, regardless of pot height and pot position on the cooktop
- Ambient Light
- Dishwasher safe metal grease filters
- Saturation display for filters
- The glass panel can be easily removed and cleaned

Connectivity

- Remote Monitoring and Control for connected home appliances and operation via smartphone or tablet (only in countries where Home Connect service is available)
- The Home Connect functionality can be extended by integrating numerous applications from external cooperation partners (partnerships)
- Voice Control enabled via popular voice assistants (only in countries where this service is available)
- interval function: available via Home Connect
- silence function: available via Home Connect

Performance

- Extraction rate according to EN 61591 ø 15 cm:
max. Normal use 501 m³/h
Intensive 775 m³/h
- Noise level according to EN 60704-3 exhaust air:
Max. normal use: 62 dB(A) re 1 pW
Intensive: 70 dB(A) re 1 pW
- Noise min./max. Normal Level: 39/62 dB
- With the Clean Air Plus recirculation kit (available as accessory) your appliances reaches:
Extraction rate in recirculation mode:
Max. normal use: 416 m³/h
Intensive: 525 m³/h
Noise level in recirculation mode:
Max. normal use: 65 dB(A) re 1 pW
Intensive: 70 dB(A) re 1 pW
- Efficient BLDC-technology

Planning and installation information

- Extension height 250 mm
- Appliance dimensions (HxWxD): 709 x 816 x 140 mm
- Built-in dimensions (HxWxD): 703 x 781 x 123 mm
- Electrical cable length 1.3 m
- For remote motor installation special accessory kit is needed
- Please reference the built-in dimensions provided in the installation drawing
- Combination with gas cooktops not allowed

Consumption Data

- Average Energy Consumption: 36.9 kWh/year
- Power rating: 300 W

Serie | 8, downdraft hood, 80 cm, clear glass DDW88MM66

measurements in mm

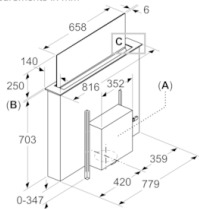

A: The motor unit can be fitted on the front or the rear or offset at a distance from the appliance. (Special accessory required)
B: 5.5

Measurements in mm

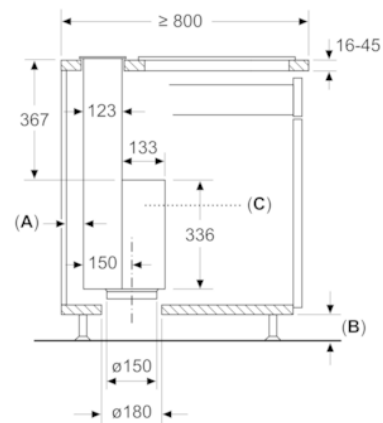

A: ≥ 20 mm between the Guided Air suction area and a cabinet wall

B: ≥ 60 mm for air recirculation

≥ 100 mm for air extraction with ducting

Measurements in mm
Combination with electric hob

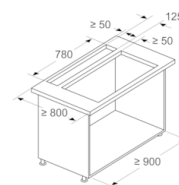

Combination with gas hob is not possible

To prevent power loss, observe the following:

- Do not install upper cabinets above the appliance
- Clearance of open shelf elements above the appliance min. 650 mm (recommended)
- Left/right clearance between appliance and wall/adjacent upper cabinet min. 500 mm
- Clearance between appliance frame and wall min. 50 mm

Measurements in mm
Seamless installation
(Special accessory required)

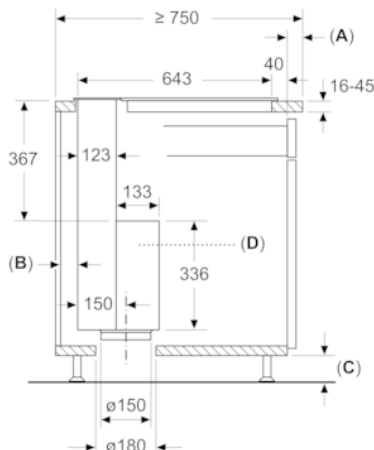

A: Worktop overhang protruding beyond unit carcass

B: ≥ 20 mm between the Guided Air suction area and a cabinet wall

Measurements in mm
Combination with electric hob
Seamless installation

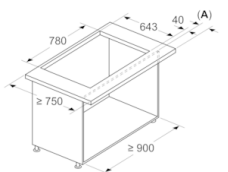

A: Worktop overhang protruding beyond unit carcass

Combination with gas hob is not possible

To prevent power loss, observe the following:

- Do not install upper cabinets above the appliance
- Clearance of open shelf elements above the appliance min. 650 mm (recommended)
- Left/right clearance between appliance and wall/adjacent upper cabinet min. 500 mm
- Clearance between appliance frame and wall min. 50 mm

Planning information for recirculation mode

If the appliance is installed in front of a poorly insulated external wall with a U-value >0.5 W/(m² K), we recommend fitting an air duct up to the plinth panel in recirculation mode.

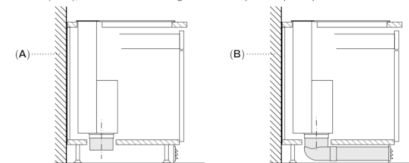

A: External wall – U-value ≤ 0.5 W/(m² K)
B: External wall – U-value > 0.5 W/(m² K)