

**Series 8, washing machine, front loader, 10 kg, 1400 rpm
WGH25400AU**



An advanced washing machine with ActiveWater Plus which saves up to 50% water and reduces your ironing pile with Iron Assist.

- **Iron Assist:** Reduce wrinkles up to 50%.
- **Added Steam:** Less ironing, more time for you.
- **ActiveWater Plus:** For highly efficient use of water even with smaller loads thanks to automatic load detection.
- **Speed Perfect:** Perfectly clean in up to 65% less time. ¹
- **AntiStain :** Reliably removes 16 different stubborn stains without any additional pre-treatment.

Maximum capacity in kg :	10.0 kg
Built-in / Free-standing:	Free-standing
Dimensions of the product:	845x598x590 mm
Net weight:	75.0 kg
Connection rating:	2300 W
Fuse protection:	10 A
Voltage:	220-240 V
Frequency:	50 Hz
Length electrical supply cord:	210 cm
Door hinge:	Left
Wheels:	No
EAN code:	4242005528660
Installation type:	Free-standing



WMZ2200 Floor securing component

¹ Difference between the duration of Easy Care program 40°C and the duration of Easy Care program 40°C with SpeedPerfect. Duration of time saved varies based on load size.

Series 8, washing machine, front loader, 10 kg, 1400 rpm WGH25400AU

An advanced washing machine with ActiveWater Plus which saves up to 50% water and reduces your ironing pile with Iron Assist.

Capacity

- Capacity: 10 kg

Consumption rates

- 5.5 Stars
- Energy consumption 181 kWh kWh per year, based on Cottons Eco 60°C program at 1400 RPM seven times per week. When tested in accordance with AS/NZS 2040.2. Actual energy use and running costs will depend on how you use the appliance.
- 5 Star Water rating (WELS)
- Water consumption 72 l litres per wash. Using the Cottons Eco program at 60°C with 1400 RPM spin speed. In accordance with AS/NZS 6400. Actual water consumption will depend on how the appliance is used. C46069.

Design

- Elegant and ergonomically inclined control panel for easy use
- Illuminated control dial with integrated power On/Off button
- Large LED display for program status, temperature, spin speed, and time remaining

Programs

- Standard programs:
 - Cottons: hard-wearing items made from cotton, linen or blended fabrics
 - Cotton Eco: energy-saving program
 - Easy care: items made from synthetic or blended fabrics
 - Delicate/Silk: delicate, washable items made from silk, viscose and synthetics
 - Wool: hand or machine washable items that are made from wool or contain wool
- Additional specialty programs:
 - App
 - Iron Assist - with added steam for wrinkle reduction
 - Hygiene Plus
 - Jeans/dark laundry
 - Spin/Drain: spins and drains the water
 - Mixed: lightly soiled items made from cotton, linen or blended fabrics
 - Sportswear: sports and leisure items made from synthetic fibres, microfibre or fleece
 - Rinse: rinses and then spins the laundry, and then drains the water
 - Super 15'/30': short program for small lightly soiled items
- TouchControl buttons include:
 - Prewash options for stubborn stains and heavily soiled garments
 - Finish in (delayed start): delay the start of the program by up to 24 hours
 - Spin Speed: manually adjust the spin speed
 - AntiStain: Selection options of Grass, Red Wine, Oil/Butter and

Blood

- Start/Pause with Reload function: allows you to add a forgotten garment even after the wash cycle has started
- Steam
- Temperature selection: manually adjust the temperature
- SpeedPerfect: reduce cleaning time by up to 65%
- Prepare Start: before you press "Start"
- Remote Start
- programmes via app: Shirts

Features

- Iron Assist: Steam programme that reduces wrinkles on dry clothes
- Wrinkle Guard: Gentle drum rotation after the wash cycle to avoid wrinkles
- The option "Added Steam" can reduce wrinkles by up to 40% during the wash cycle.*****
- Stain automatic - 6 stains at the touch of a button, 10 further stains via Home Connect
- ActiveWater Plus: for highly efficient use of water even with small loads thanks to automatic load detection.
- Reload function to pause machine operation for adding in last minute laundry items
- Hygiene Plus: clean laundry and killing germs effectively
- Self cleaning detergent drawer to remove detergent residue, From front
- Automatic load detection
- XXL Drum volume: 70 l
- LED interior drum light bathes the inside of the drum in a brilliant white light when opened
- EcoSilence Drive: quiet, durable, and energy-efficient brushless motor (BLDC) with 10-year motor warranty
- VarioDrum: thorough yet gentle washing thanks to the unique drum structure design
- AntiVibration Side Panels reduce vibrations and noise levels, making it extremely quiet during the spin cycle
- Aqua Protection Plus anti-flood protection with self-sealing hose, minimises the risk of flooding
- Home Connect: Remote Monitoring and Control, Energy Management, Remote Diagnostics, further programmes via download. Always keep your appliance up to date via firmware update.
- Foam detection system to remove excessive foam
- Overdosage indication
- Unbalanced load detection
- Buzzer at the end of the programme

Performance

- Spin speed 400 - 1400 rpm
- Operating noise level (based on Cotton 60°C program): wash 52 / 74 spin dB(A)

Technical Information

- Slide-under height of 85cm
- Dimensions (H x W x D): 845 mm x 598 mm x 590 mm

Safety

- Child safety control lock
- Spin speed 0 - 1400 rpm

** The maximum spin speed is automatically reduced in the case of laundry imbalances.



test5

**Series 8, washing machine, front loader, 10 kg, 1400 rpm
WGH25400AU**

Measurements in mm

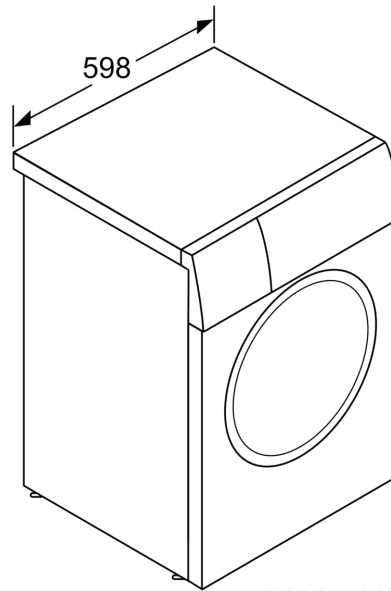
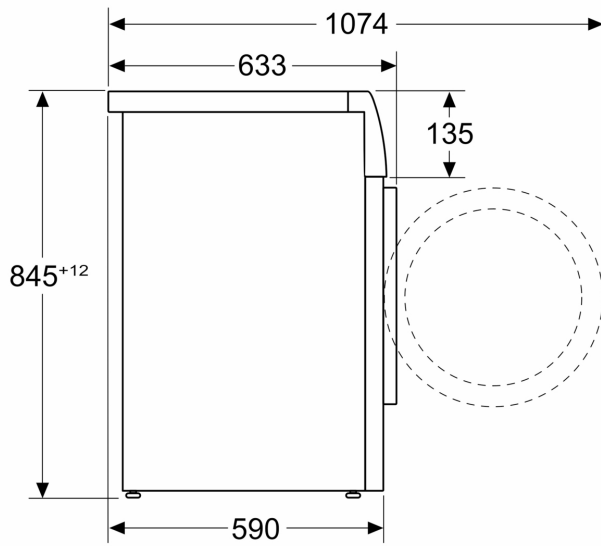

measurements in mm