

60cm built-under matte black dishwasher with 8 wash programs, featuring ComfortLift basket, MaxiFlex cutlery drawer, ComfortRails and ProClean™ satellite spray arm to deliver a perfect wash result, regardless of your load.

RRP AUS \$2,699.00



Product Details

FEATURES

ComfortLift
ComfortLift for effortless loading and unloading.

MaxiFlex
Accommodate different kitchen tools with MaxiFlex.

GlassCare
GlassCare protects and gently cleans glassware.

ExtraPower
ExtraPower use a boost to remove stubborn dirt.

SatelliteClean
ProClean Satellite Spray reaches every corner.

AirDry
AirDry uses natural airflow for better drying.

ExtraHygiene
ExtraHygiene for hygienic dish cleaning.

ExtraSilent
ExtraSilent operates quietly at only 44dB(A).

BENEFITS

LIFT GENTLE TO A NEW LEVEL

Our ComfortLift dishwasher lets you gently slide and lift the lower basket upwards. With a dishwasher designed around your needs, you can load and unload more efficiently and stack more effectively. With ComfortLift we've elevated dishwashing to a whole new level.

DARE TO USE EVERY KITCHEN TOOL

The MaxiFlex drawer is designed to fit cutlery and utensils of different shapes and sizes. Its increased depth offers greater capacity in each load. Whether large or awkwardly-shaped, the customisable dividers and deep drawer mean everything can be loaded with ease.

GENTLE CARE FOR YOUR GLASSWARE

The unique SoftGrip feature ensures that the stem and foot of every glass are held gently but firmly in exactly the right position throughout the duration of the program. Protected from vibration. Removing the risk of breakages. And with SoftSpikes you no longer need to spend time handwashing delicate glasses. The soft material gently holds glasses securely in place and protects them from cracks and breakage.

IMPROVE WASHING RESULTS

ExtraPower function improves the washing results of the selected program. The extra boost in wash temperature and duration rids stubborn stains from your kitchenware with immaculate results.

REACH EVERY CORNER

The ProClean powerful, double rotating satellite spray arm, with 5 spray levels, sprays from continuously varying angles ensuring maximum water coverage over your entire load for an immaculate wash result.

THE DOOR TO AUTOMATIC DRYING

Our AirDry technology lets you maximise your drying performance with natural airflow. The door automatically opens up to 10cm when the cycle is complete. It dries your dishes naturally meaning spotless, cared for glasses every time.

HYGIENIC CARE FOR YOUR DISHES

The ExtraHygiene function gives you maximum cleaning performance with hygienic care. With the ExtraHygiene function, the final rinse phase heats up to 69°C and keeps the temperature high for minimum 10 minutes to sanitize your dishes.

ENJOY THE SILENCE

At a low of 44dB(A), ExtraSilent program noise level is so low you will barely know its there. Good by to noise and say hello to silence.

Specifications

PRODUCT PROFILE

Domestic warranty details (yrs)	5
Type of Dishwashers	built under
Place settings	14
Drying system	AirDry
Number of spray arms	3
Top shower	Yes

DIMENSIONS

Total height (mm)	818
-------------------	-----

SPECIFICATION

Water Efficiency Star Rating	5
WELS Registration Number	D02719
Water consumption (litres)	11.2
Energy Efficiency Star Rating	3.5
Energy consumption cold water (kWhr/yr)	273
Noise level dBA	44
Water supply	cold or hot (maximum 60°C)
Basket colour	grey
Service cord length	1600
Inverter system	Yes

WASH PROGRAMS

Number of Programs	8
--------------------	---

DIMENSIONS

Total width (mm)	597
Total depth (mm)	576
Cabinet requirement excluding worktop (height)	820-880
Cabinet requirement excluding worktop(width)	600
Cabinet requirement excluding worktop (depth)	570

CONTROL PANEL

Control panel type	LCD display
Control panel finish	black
Display indicators	time remaining,rinse aid,service code,program selected,delay start,GlassCare,ExtraPower,ExtraHygiene

EXTERIOR

Door finish	black
Side colour	black

WASH PROGRAMS

Programs	Quick 30 min,Extra Silent,Regular 90 min,AUTO Sense,Machine Care,Light 60 min,Heavy 160 min,ECO 180 min
Wash option	Delay start (1-24 hours),GlassCare,ExtraPower,ExtraHygiene
Range of temperatures	4

FEATURES

Other Features	interior light,Auto Off,MaxiFlex drawer with ComfortRails
Water safety system	aqua control
Dispenser	detergent,rinse aid

UPPER BASKET

Upper basket features	soft spikes for tall glass,SoftGrip,Foldable glass rack,ComfortRail,easy lift adjustable upper basket
-----------------------	---

EXTERIOR

Plinth colour (kickboard)	no plinth supplied
Removable worktop	No

LOWER BASKET

Lower Basket Features	ComfortLift
Foldable Racks	4
Foldable cup shelves	0

HOSES

Inlet hose length	1800
Drain hose length	1800
extension hose	spare part

UPPER BASKET

Foldable cup shelves	4
Foldable Racks	2

THIRD TRAY

Tray features	Cutlery Tray
---------------	--------------

SHIPPING

Shipping Volume (m3)	0.376
Shipping Weight (Kg)	47.7
Pack Dimensions Height (mm)	870
Pack Dimension Width (mm)	635
Pack Dimension Depth (mm)	680

STUFFING QUANTITIES

40ft HC	150
---------	-----

Dimensions

Model:
FUF9490SMA

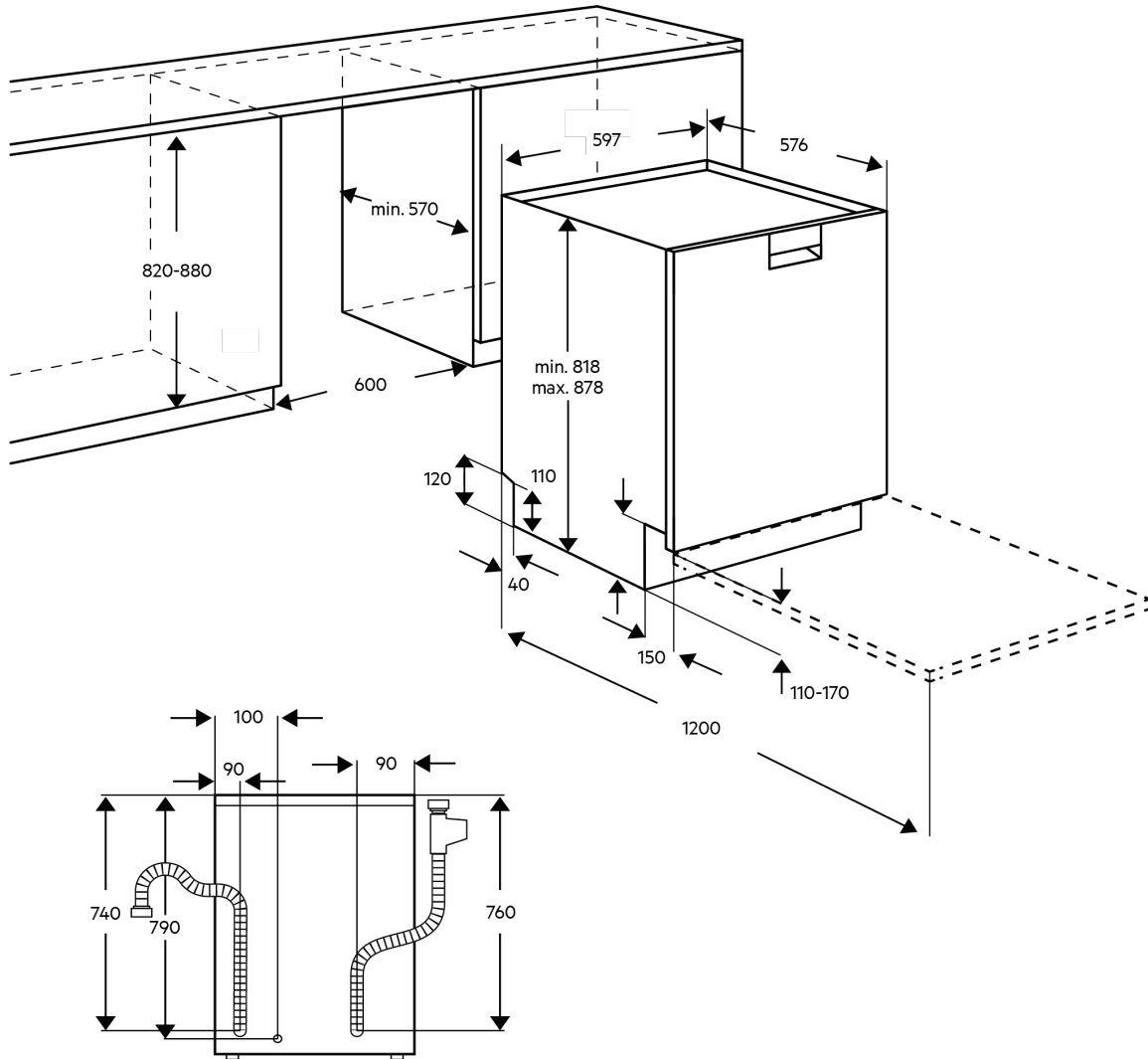

© 2024 Electrolux S.E.A PTE. LTD. AEG_IM_Diag_FUF9490SMA_Nov24

Terms and Conditions

IMPORTANT

This is a guide of product dimensions only. For complete installation instructions, refer to the manual provided with product.

PRODUCT INFORMATION

The descriptors and illustrations in this publication apply to the specific products and models described as at the date of issue. Under our policy of continuous product development, product specifications may change without notice. Prospective purchasers should therefore check with their retailer to ensure this publication correctly describes the products that are being offered for sale. All information supplied is to be used for general reference purposes only and is on the understanding that Electrolux Home Products Pty Ltd (Australia) and Electrolux (NZ) Ltd (New Zealand) will not be liable for any loss, liability or damage of whatever kind arising as a result of reliance on such information. Colours of products illustrated are as close as printing limitations allow. Electrolux will at all times comply with its obligations pursuant to law including Trade Practices (Australian Consumer Law) Act and Regulations.

WARRANTY

Electrolux Home Products warrants that for domestic applications the AEG appliances featured are free from defects in materials and workmanship for 5 years (3 months warranty for commercial applications). All warranties are subject to the conditions set out in the warranty card accompanying the product when purchased.

ELECTROLUX HOME PRODUCTS AUSTRALIA

telephone: 1300 363 664

fax: 1800 350 067

email: customercare@aegaustralia.com.au

web: www.aeg.com/au

ELECTROLUX HOME PRODUCTS NEW ZEALAND

telephone: 0800 10 66 10

fax: 09 573 2221

email: customercare@electrolux.co.nz

web: www.aeg.com/au